

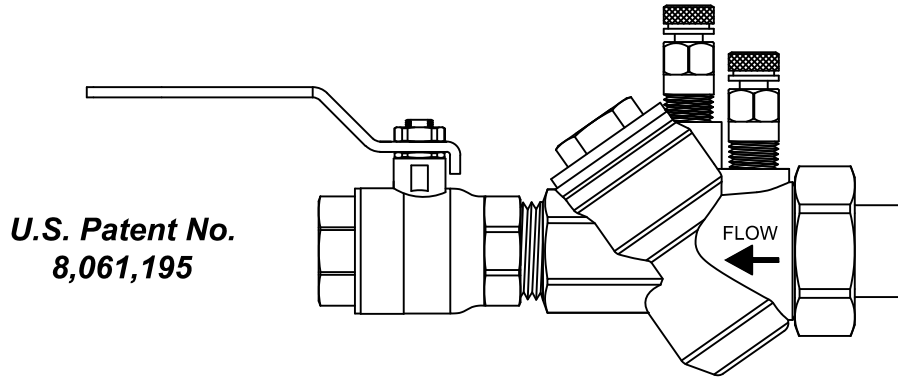

AFLB Series Specifications

Automatic Pressure Independent Flow Limiter w/ Ball Valve

- A: AFLB - ½" - 1" High
- B: AFLB - 1" High - 1½" Low
- C: AFLB - 1½" High - 2"



PRODUCT DESCRIPTION: The AFLB is an Automatic Pressure Independent Flow Limiting device, male ended by union with a brass ball valve attached, rated at 600 WOG / CWP @ 250° F. The AFLB is supplied with a stainless steel flow limiting cartridge that can be removed for cartridge exchange, if necessary. The AFLB comes standard with two pressure/temperature ports and a hanging identification tag. The ball valve end, or run-out side, is available in FNPT or SWT. The union side connections available include MNPT, FNPT, SWT, and a variety of reductions.

STANDARD MATERIAL SPECIFICATIONS		STANDARD OPERATING SPECIFICATIONS	
Body	Forged Brass ASTM B283-06 or Cast Brass ASTM B763-08A	Control Range:	2 psi - 60+ psi
O-Ring	EPDM	Accuracy:	±5%
Tail Piece, Packing Nut	Brass ASTM B124-09, B228-06, or B763-08A	Max Working Pressure:	600 WOG / CWP
Union Nut	Brass ASTM B455	Max Operating Temperature:	40°F to 250°F
Flow Cartridge	ASTM A582 Type 303 Stainless Steel	Start-Up Head Loss:	5 Feet of H ₂ O
Diaphragm	EPDM	Specification information is provided to assist and is given without obligation or warranty. The Company reserves the right to make changes in design, materials, and/or specifications without notice or liability.	
Spring	302 Stainless Steel		
PT Port	EPDM Dual Durometer Core		
Ball Valve	Forged Brass ASTM B283-06		
Stem	Brass ASTM B124-09 - Blow-Out Proof		
Ball	Chrome Plated Brass		
Ball Seat, Packing Gland	Teflon		
Handle	Chrome Plated Steel w/ Vinyl Cover		

Valve Size	FLOW RATES (GPM) * CONTROL RANGE 2 - 60+ PSID **																									
	A	B	C	D	E	F	G	H	I	J	K	L	M	N	O	P	Q	R	S	T	U	V	W	X	Y	Z
A ½" - 1" L	.33	.50	.75	1	1.25	1.5	1.75	2	2.25	2.5	2.75	3	3.5	4	4.5	5	5.5	6	6.5	7	7.5	8	9	10	11	12
B 1" H - 1½" L	5	5.5	6	6.5	7	8	9	10	12	13	14	15	16	18	20	22	24	26	28	30	32	34	36	38	40	42
C 1½" H - 2"	15	20	25	30	35	40	45	50	55	60	65	70	75	80	85	90	95	100	110	120	130	140	150	160	170	180

* Custom flow rates can be calibrated at the factory for an additional charge.
 Unless confirmed as special, flow rates will default to standard flow rate.

PRODUCT SPECIFICATIONS:

- The Automatic Flow Limiter with Ball Valve (AFLB) shall have flow measurement capability
- The AFLB shall have a static orifice to control flow
- The AFLB Cartridge shall be permanently marked with the letter that corresponds to the factory preset GPM
- All flow cartridge wear surfaces shall be stainless steel
- The AFLB shall have a 2 PSID start up rating
- The AFLB Cartridge shall have a large operational differential range
- The AFLB Cartridge shall provide continual flow at differential pressures above design limits
- The AFLB Cartridge shall be removable for cleaning or exchange if required



AFLB Series Dimensions

Automatic Pressure Independent Flow Limiter w/ Ball Valve

A: AFLB - 1/2" - 1" L

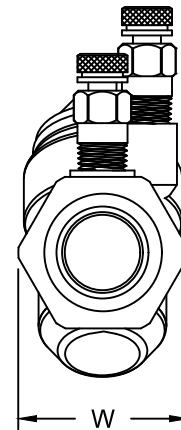
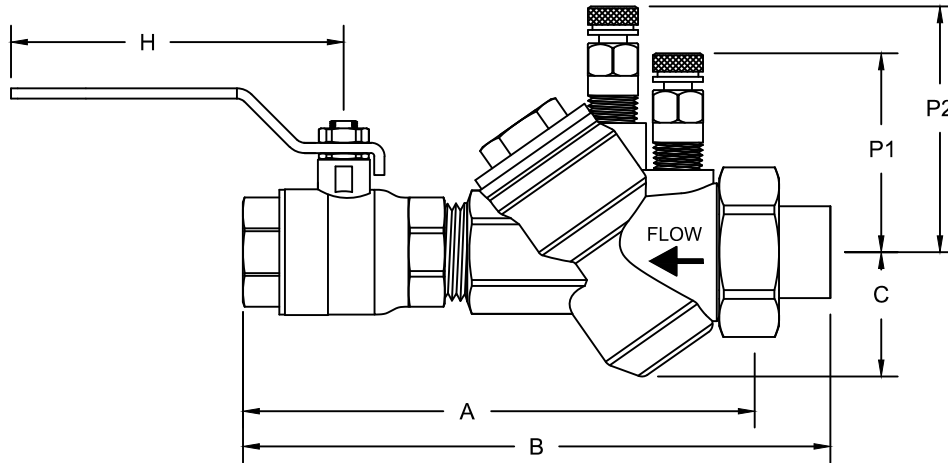

BALL VALVE SIZE AND TYPE	A	TAIL PIECE	B	WEIGHT (lbs)	C	H	P1	P2	W
1/2" SWT	5.7	- M	7.3	1.8	1.3	3.7	2.3	2.8	1.7
		- F	6.4	1.8					
		- S	6.4	1.7					
1/2" FPT	5.4	- M	7.0	1.8	1.3	3.7	2.3	2.8	1.7
		- F	6.0	1.8					
		- S	6.0	1.7					
3/4" SWT	6.6	- M	8.1	2.4	1.4	3.8	2.0	2.6	1.8
		1/2" - F	7.3	2.4					
		- S	7.3	2.4					
		- M	8.3	2.5					
		3/4" - F	7.2	2.4					
		- S	7.2	2.4					
3/4" FPT	6.1	- M	7.5	2.4	1.4	3.8	2.0	2.6	1.8
		1/2" - F	7.2	2.5					
		- S	6.8	2.4					
		- M	7.8	2.5					
		3/4" - F	7.0	2.4					
		- S	6.8	2.4					
1" SWT	7.3	1/2" - M	9.5	3.5	1.2	5.0	2.0	2.5	2.1
		3/4" - M	9.5	3.5					
		- S	8.2	3.3					
		- M	9.5	3.6					
		1" - F	8.5	3.4					
- S	8.5	3.3							
1" FPT	6.7	1/2" - M	8.7	3.5	1.2	5.0	2.0	2.5	2.1
		3/4" - M	8.7	3.5					
		- S	7.5	3.3					
		- M	8.7	3.6					
		1" - F	7.6	3.4					
- S	7.6	3.3							

Note: Dimensions listed above do not include ProPress or any other special fittings or adapters. All dimensions, weights, and materials are subject to minor variations. Consult with factory for confirmation of dimensions and material specifications. Sweat size listed is nominal and will differ from the actual, measurable size.



AFLB Series Dimensions

Automatic Pressure Independent Flow Limiter w/ Ball Valve B: AFLB - 1" H - 1½" L

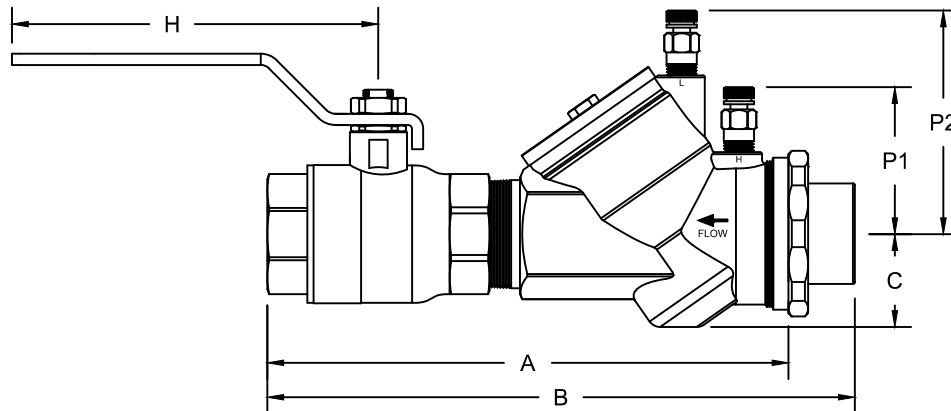

BALL VALVE SIZE AND TYPE	A	TAIL PIECE	B	WEIGHT (lbs)	C	H	P1	P2	W
1" SWT	8.6	- M	10.6	5.3	1.4	5.0	2.3	2.6	3.9
		- F	9.5	5.2					
		- S	9.5	5.1					
1" FPT	8.0	- M	10.0	5.3	1.4	5.0	2.3	2.6	3.9
		- F	8.8	5.2					
		- S	9.0	5.1					
1¼" SWT	9.1	- M	11.0	6.2	1.4	5.0	2.3	2.6	3.9
		- F	11.1	6.3					
		- S	10.5	5.9					
		- M	11.1	6.3					
		- F	10.1	6.0					
		- S	10.2	5.9					
1¼" FPT	8.3	- M	10.3	6.2	1.4	5.0	2.3	2.6	3.9
		- F	9.3	6.0					
		- S	9.6	5.9					
		- M	10.3	6.3					
		- F	9.0	5.8					
		- S	9.5	5.9					
1½" SWT	9.4	- M	11.9	6.5	1.4	6.3	2.5	3.4	3.2
		- F	11.9	6.6					
		- S	10.9	5.9					
		- M	11.9	6.4					
		- F	10.6	6.1					
		- S	10.6	5.9					
1½" FPT	9.0	- M	11.0	6.4	1.4	6.3	2.5	3.4	3.2
		- F	11.0	6.5					
		- S	10.0	5.8					
		- M	11.0	6.3					
		- F	9.7	6.0					
		- S	9.7	5.8					

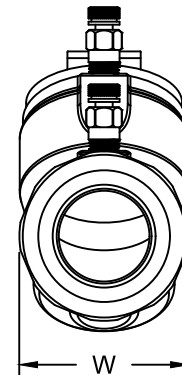

Note: Dimensions listed above do not include ProPress or any other special fittings or adapters. All dimensions, weights, and materials are subject to minor variations. Consult with factory for confirmation of dimensions and material specifications. Sweat size listed is nominal and will differ from the actual, measurable size.



AFLB Series Dimensions

Automatic Pressure Independent Flow Limiter w/ Ball Valve

C: AFLB - 1½" H - 2"

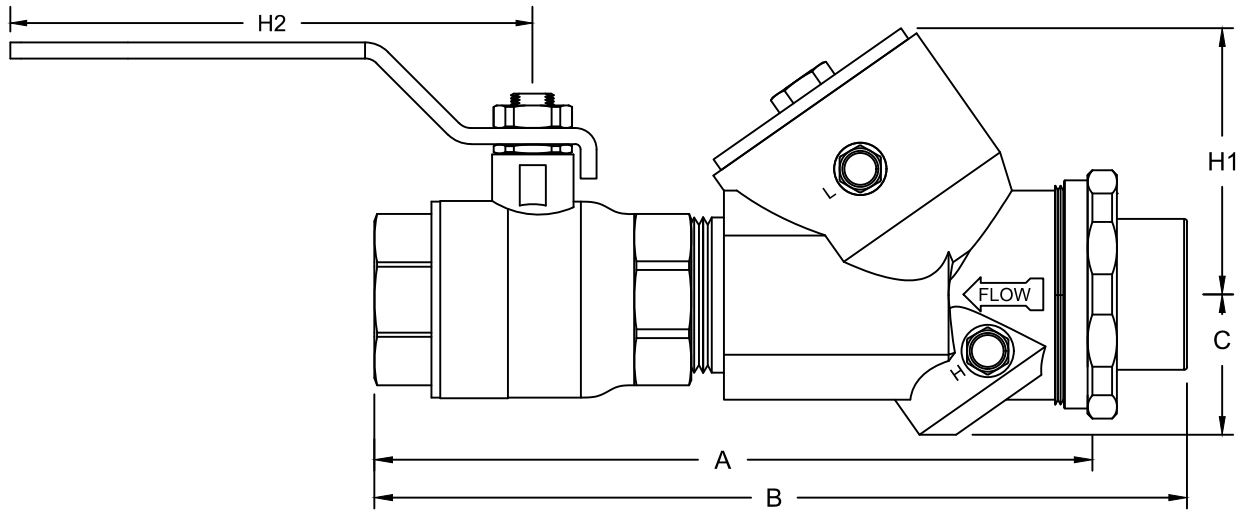

BALL VALVE SIZE AND TYPE	A	TAIL PIECE	B	WEIGHT (lbs)	C	H1	H2	P	W
1½" SWT	12.3	- M	15.3	14.7	2.2	4.2	6.3	3.2	3.7
		1¼" - F	15.3	14.6					
		- S	14.0	13.8					
		- M	15.0	15.1					
		1½" - F	15.3	14.8					
		- S	13.8	13.8					
1½" FPT	11.5	- M	14.5	14.7	2.2	4.2	6.3	3.2	3.7
		1¼" - F	14.5	14.6					
		- S	13.0	13.8					
		- M	14.5	15.1					
		1½" - F	14.5	14.8					
		- S	13.1	13.8					
2" SWT	11.7	- M	14.7	15.5	2.2	4.2	6.2	3.2	3.7
		1½" - F	14.7	15.5					
		- S	13.3	14.6					
		- M	14.7	15.5					
		2" - F	12.8	14.9					
		- S	13.2	14.5					
2" FPT	10.6	- M	13.6	15.4	2.2	4.2	6.2	3.2	3.7
		1½" - F	13.6	15.4					
		- S	12.2	14.5					
		- M	13.6	15.4					
		2" - F	11.8	14.8					
		- S	12.0	14.4					

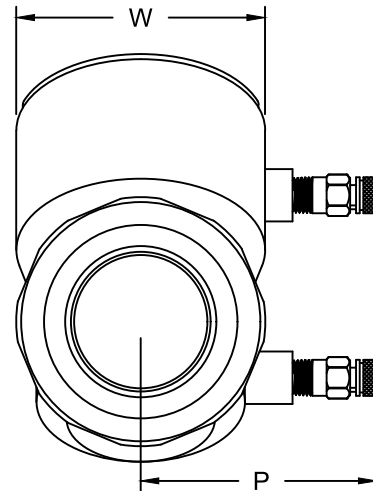

Note: Dimensions listed above do not include ProPress or any other special fittings or adapters. All dimensions, weights, and materials are subject to minor variations. Consult with factory for confirmation of dimensions and material specifications. Sweat size listed is nominal and will differ from the actual, measurable size.

PRO *Hydronic* *Specialties*

AFLB Series Submittal

Automatic Pressure Independent Flow Limiter w/ Ball Valve

- A: AFLB - 1/2" - 1" L
- B: AFLB - 1" H - 1 1/2" L
- C: AFLB - 1 1/2" H - 2"

U.S. Patent No.
8,061,195

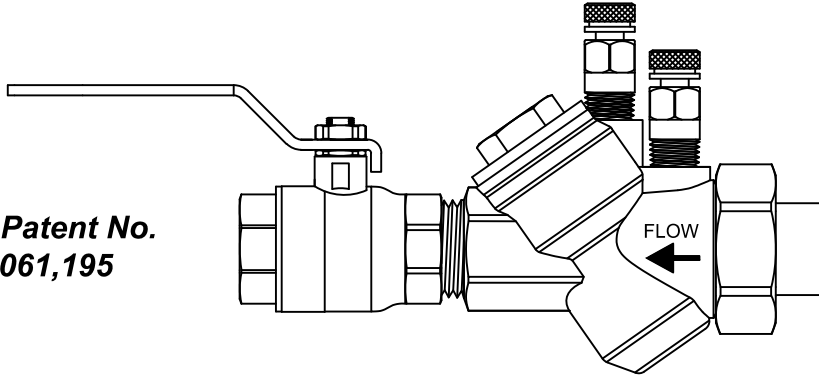

AFLB - X - X - X - X - X - X - XX,

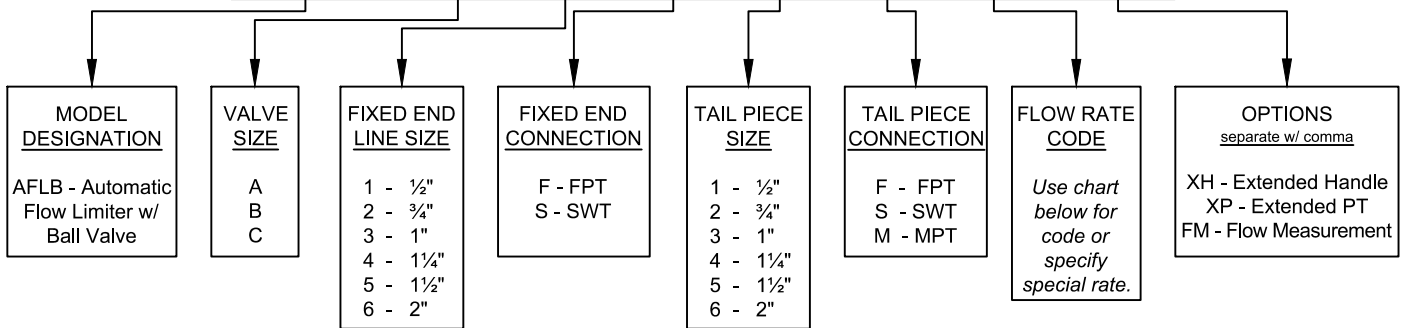

Valve Size	FLOW RATE CODES (GPM)* CONTROL RANGE 2 - 60+ PSID **																									
	A	B	C	D	E	F	G	H	I	J	K	L	M	N	O	P	Q	R	S	T	U	V	W	X	Y	Z
A 1/2" - 1" L	.33	.50	.75	1	1.25	1.5	1.75	2	2.25	2.5	2.75	3	3.5	4	4.5	5	5.5	6	6.5	7	7.5	8	9	10	11	12
B 1" H - 1 1/2" L	5	5.5	6	6.5	7	8	9	10	12	13	14	15	16	18	20	22	24	26	28	30	32	34	36	38	40	42
C 1 1/2" H - 2"	15	20	25	30	35	40	45	50	55	60	65	70	75	80	85	90	95	100	110	120	130	140	150	160	170	180

* Custom flow rates can be calibrated at the factory for an additional charge.
 Unless confirmed as special, flow rates will default to standard flow rate.

JOB NAME:		REPRESENTATIVE:	
ENGINEER:		REF/PO#:	
CONTRACTOR:		SUBMITTED BY:	
		DATE:	
		DATE:	
PART # (See table above)	TAGGING/JOB INFORMATION	GPM	QUANTITY



IVS Series Specifications

Integral Ball Valve/Wye Strainer/Union

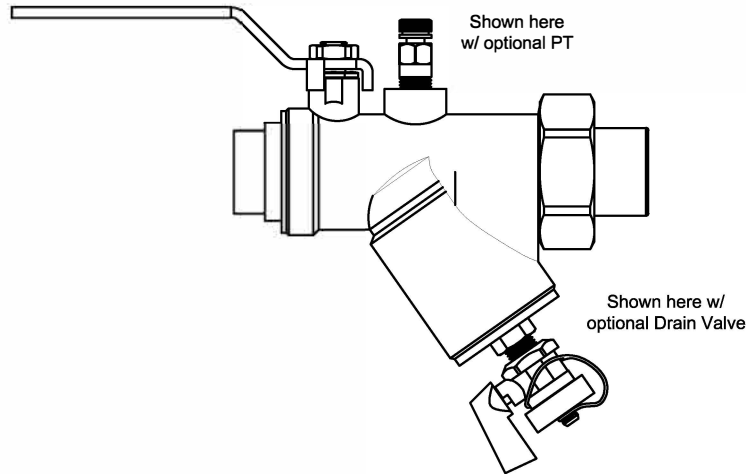

PRODUCT DESCRIPTION: The IVS is an integral ball valve, wye-strainer and union. The IVS uses a full-port ball valve for positive shut-off and offers two (2) predrilled 1/4" taps for accessories to be installed. The strainer has a 20-mesh stainless steel screen to aid in debris removal. The strainer cap has a 1/4" tap for a hose-end drain valve. The ball valve has a PTFE packing gland, brass packing nut, and blow-out proof double o-ring stem seal. The fixed end connections may be FNPT or SWT. The union side connections include MNPT, FNPT, SWT, and a variety of reductions.

STANDARD MATERIAL SPECIFICATIONS		PORT LOCATIONS
Body	Forged Brass ASTM B283-06, or cast Brass ASTM B763-08A	
O-Ring	EPDM	
Tail Piece	Brass ASTM B124-09, B228-06, or B763-08a	
Union Nut	Brass ASTM B455	
PT Seal	EPDM Dual Durometer Core	
Handle	Chrome Plated Steel	
Stem	Brass ASTM B124-09 - Blow-Out Proof	
Ball	Chrome Plated Brass - Full Port	
Ball Seat	Teflon	
Packing Gland	Teflon	
Packing Nut	Brass ASTM B124-09, B228-06, or B763-08a	
STANDARD OPERATING SPECIFICATIONS		
Maximum Working Pressure:	600 WOG / CWP	
Maximum Operating Temperature:	40° F to 250° F	
<p>Specification information is provided to assist and is given without obligation or warranty. The Company reserves the right to make changes in design, materials, and/or specifications without notice or liability.</p>		

PRODUCT SPECIFICATIONS:

- Device shall have a full port isolation valve
- Device shall have a 20 mesh accessible strainer sleeve
- Device shall have a blow down for debris removal
- Device shall have a functional by-pass
- The strainer screen shall have a minimum 8:1 ratio of total area against the internal pipe diameter



IVS Series Dimensions
Integral Ball Valve/Wye Strainer/Union

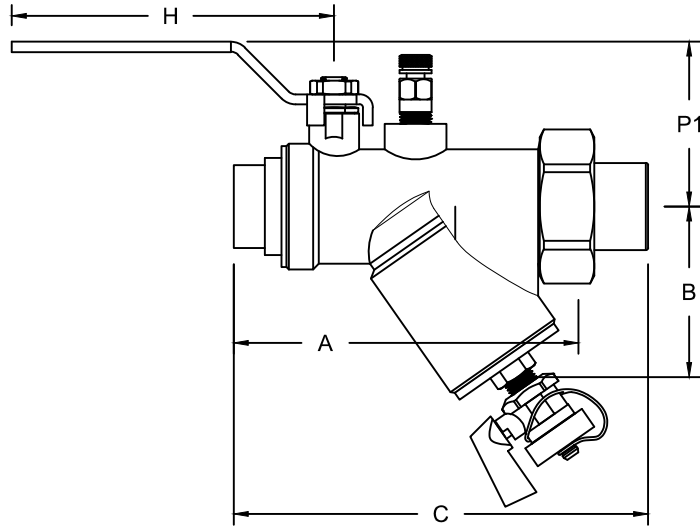

Model	Size	A	B	H	P1	* R
IVS1-SWT	1/2"	4.0	2.0	4.2	2.0	21:1
IVS2-SWT	3/4"	4.6	2.3	4.2	2.2	11:1
IVS3-SWT	1"	5.8	2.7	4.2	2.3	11:1
IVS1-FPT	1/2"	3.7	2.0	4.2	2.0	21:1
IVS2-FPT	3/4"	4.1	2.3	4.2	2.2	11:1
IVS3-FPT	1"	5.0	2.7	4.2	2.3	11:1

Note: Dimensions above do not include ProPress or any other special fittings or adapters. All dimensions, weights, and materials are subject to minor variations. Consult with factory for confirmation of dimensions, weights, and material specifications.

* R = Ratio of screen surface area to cross-sectional pipe diameter

Size	Tail Piece	C	Weight	Size	Tail Piece	C	Weight
1/2" SWT	- M	5.5	1.8	1/2" FPT	- M	5.2	1.6
	- F	4.6	1.5		- F	4.3	1.5
	- S	4.6	1.5		- S	4.3	1.5
3/4" SWT	- M	6.1	2.0	3/4" FPT	- M	5.6	2.1
	- F	5.7	2.1		- F	5.1	2.2
	- S	5.2	2.0		- S	4.7	2.0
	- M	6.2	2.1		- M	5.7	2.1
	- F	5.3	2.0		- F	4.8	2.0
	- S	5.5	2.0		- S	4.8	2.0
1" SWT	1/2" - M	7.8	3.0	1" FPT	1/2" - M	7.0	2.9
	3/4" - M	7.8	3.0		3/4" - M	7.0	2.9
	- S	6.6	2.7		- S	5.8	2.6
	- M	7.7	3.0		- M	7.0	2.9
	1" - F	6.7	2.8		1" - F	6.0	2.7
	- S	6.7	2.7		- S	6.0	2.7



IVS Series Submittal
Integral Ball Valve/Wye Strainer/Union

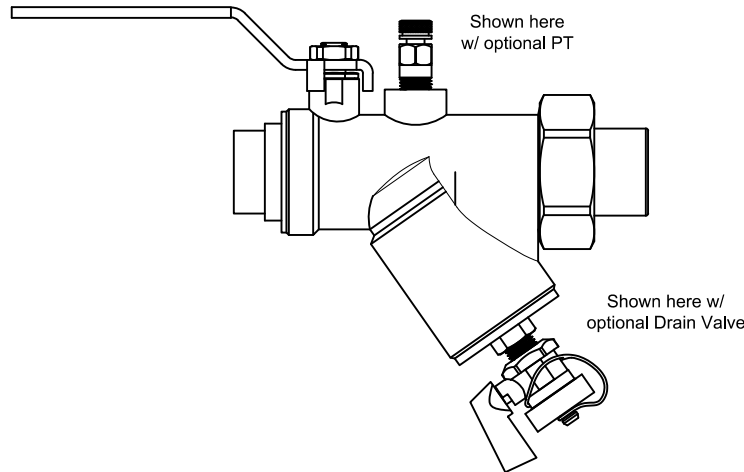

IVS - X - X - X - X - XX - XX

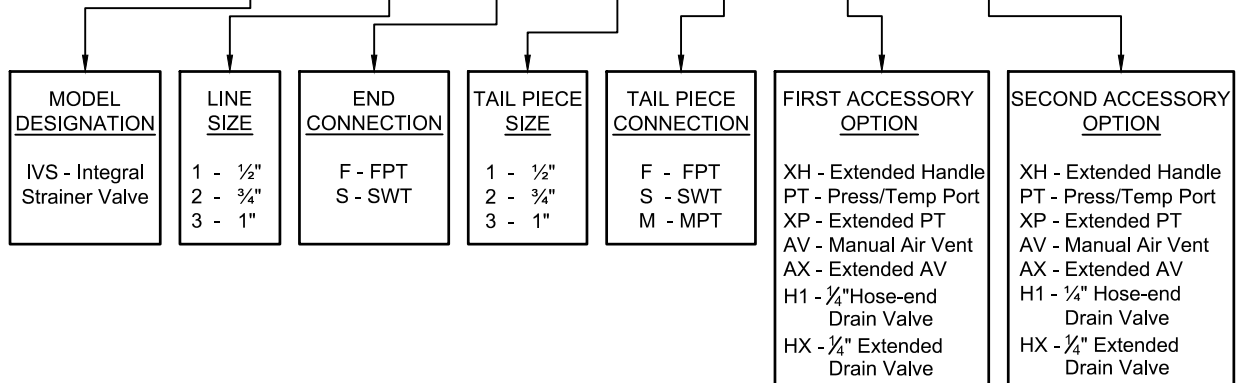

JOB NAME:		CUSTOMER:	
ENGINEER:		REF/PO#:	DATE:
CONTRACTOR:		SUBMITTED BY:	DATE:
PART # (See table above)	TAGGING/JOB INFORMATION		QUANTITY



AU Series Specifications Accessory Union

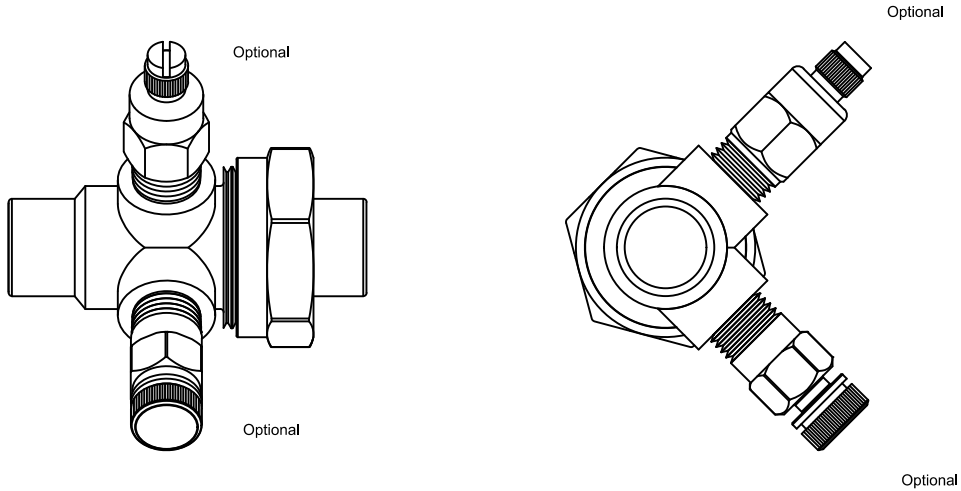

Product Description: The AU brass accessory union provides for component isolation. Port section contains two 1/4" ports that come predrilled from the factory and are positioned 90° apart. The union side incorporates an o-ring for maximum sealing protection. Accessory union comes standard with 1/4" plugs installed in the ports. Union side and port side connections available in NPTM, NPTF, and SWT. Rated at 600 WOG @ -22°F to 325°F.

STANDARD MATERIAL SPECIFICATIONS	
Accessory Union	Forged Brass ASTM B283-06
O-Ring	EPDM
Tail Piece	Brass ASTM B124-09, B228-06, or B763-08A
<p>Specification information is provided to assist and is given without obligation or warranty. The Company reserves the right to make changes in design, materials, and/or specifications without notice or liability.</p>	

PRODUCT SPECIFICATIONS:

- 1/4" ports shall be located 90° distal on a rotational axis
- Integrated ports shall provide functionality for numerous options



AU Series Dimensions Accessory Union

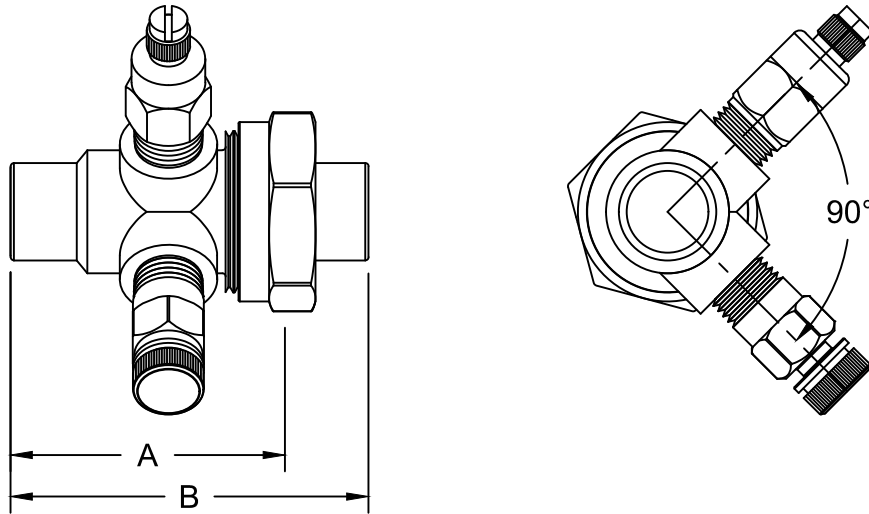

MODEL	SIZE	A	LENGTH "B" / WEIGHT OF PRO-AU AND TAIL PIECE CONNECTION											
			$\frac{1}{2}$ " M	lbs	$\frac{1}{2}$ " S	lbs	$\frac{1}{2}$ " F	lbs						
AU1M	$\frac{1}{2}$ "	2.7	4.2	0.6	3.3	0.6	3.3	0.6						
AU1S		2.1	3.7	0.5	2.8	0.4	2.8	0.5						
AU1F		2.0	3.6	0.6	2.7	0.5	2.7	0.5						
AU2M	$\frac{3}{4}$ "	2.5	4.0	0.7	3.2	0.6	3.6	0.8	$\frac{3}{4}$ " M	lbs	$\frac{3}{4}$ " S	lbs	$\frac{3}{4}$ " F	lbs
AU2S		2.1	3.7	0.6	2.9	0.5	3.3	0.6	3.8	0.6	2.9	0.5	2.9	0.6
AU2F		2.1	3.6	0.7	2.8	0.6	3.2	0.8	3.8	0.7	2.8	0.6	2.9	0.7
AU3M	1"	2.6	4.6	1.1	4.6	1.1	3.4	0.9	1" M	lbs	1" S	lbs	1" F	lbs
AU3S		2.4	4.5	1.0	4.5	1.0	3.3	0.7	4.5	1.0	3.5	0.8	3.4	0.8
AU3F		2.1	4.1	1.0	4.1	1.1	3.0	0.8	4.1	1.1	3.3	0.9	3.1	0.9
AU4M	1 $\frac{1}{4}$ "	3.0	4.7	1.7	5.0	1.8	5.0	1.9	1 $\frac{1}{4}$ " M	lbs	1 $\frac{1}{4}$ " S	lbs	1 $\frac{1}{4}$ " F	lbs
AU4S		3.0	4.7	1.5	4.9	1.7	4.9	1.7	5.0	1.8	4.1	1.5	4.0	1.6
AU4F		2.3	4.1	1.6	4.3	1.8	4.3	1.8	4.4	1.9	3.4	1.5	3.3	1.6
AU5M	1 $\frac{1}{2}$ "	3.0	4.9	2.3	5.5	2.6	5.5	2.7	1 $\frac{1}{2}$ " M	lbs	1 $\frac{1}{2}$ " S	lbs	1 $\frac{1}{2}$ " F	lbs
AU5S		3.0	4.9	2.2	5.5	2.6	5.5	2.6	5.5	2.5	4.2	2.1	4.3	2.3
AU5F		2.7	4.6	2.3	5.1	2.7	5.1	2.7	5.1	2.6	3.9	2.2	3.9	2.3
AU6M	2"	3.4	6.2	4.3	6.2	4.0	6.2	4.0	2" M	lbs	2" S	lbs	2" F	lbs
AU6S		2.8	5.8	4.0	5.8	3.6	5.8	3.6	5.8	3.7	4.2	2.7	4.0	3.0
AU6F		2.8	5.8	4.5	5.7	4.2	5.7	4.1	5.8	4.2	4.2	3.2	3.9	3.5

Note: Dimensions listed above do not include ProPress or any other special fittings or adapters. All dimensions, weights, and materials are subject to minor variations. Consult with factory for confirmation of dimensions, weights, and material specifications. Sweat size listed is nominal and will differ from the actual, measurable size.



AU Series Submittal
Accessory Union

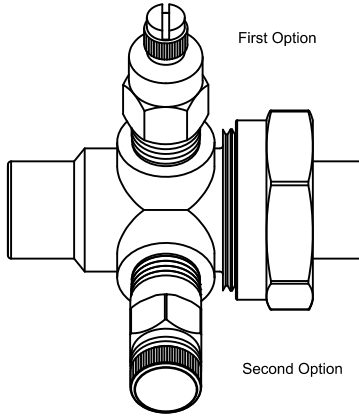

AU - X - X - X - X - XX - XX

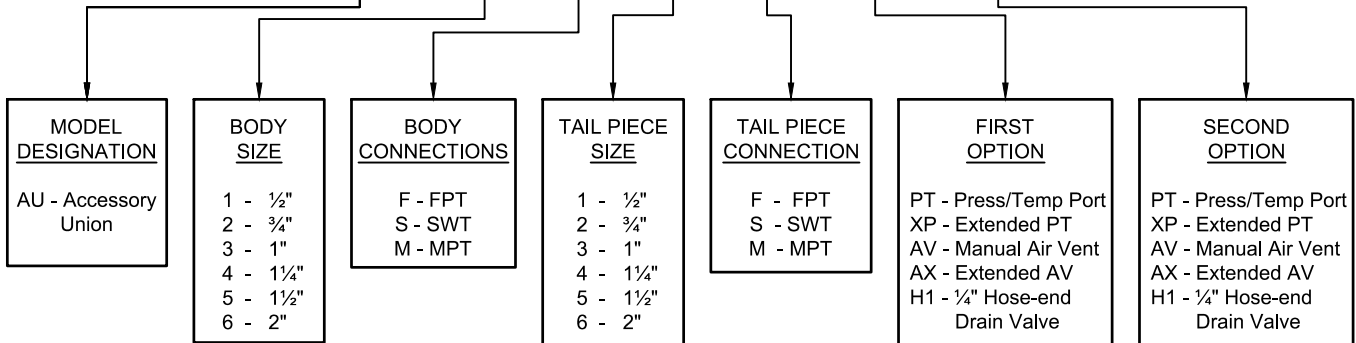

JOB NAME:		REPRESENTATIVE:
ENGINEER:		REF/PO#: DATE:
CONTRACTOR:		SUBMITTED BY: DATE:
PART # (See table above)	TAGGING/JOB INFORMATION	QUANTITY