

Manual Balancing Heat Pump Hose Kit - MHKS Submittal

	#	Size	Connection Type
Runout	1		
Coil	2		
<i>Services provided for additional fee:</i>			
Extended Components	<input type="checkbox"/>	Yes	<input type="checkbox"/> No
Stainless Steel Trim	<input type="checkbox"/>	Yes	<input type="checkbox"/> No
Bag N Tag	<input type="checkbox"/>	Yes	<input type="checkbox"/> No

* 3/8" Coil Size available in SWT ONLY.

** ProPress fittings supplied for additional fee.

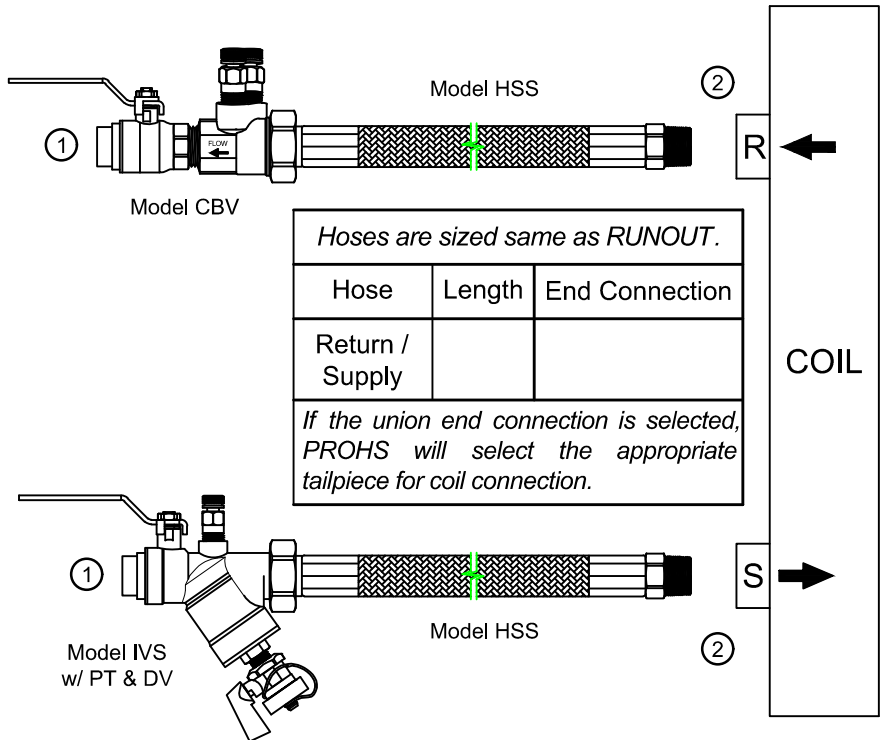

PRODUCT DESCRIPTION: The Manual Balancing Hose Kit is a packaged and partially preassembled grouping of components required to complete installation of a terminal unit. Temperature control valves, piping, and coils are supplied "by others". Mounting and testing of the customer supplied TCV is available at an additional charge.

QUANTITY	GPM	TAGGING INFORMATION
JOB NAME		REPRESENTATIVE
ENGINEER		REF/PO#
CONTRACTOR		SUBMITTED BY
		DATE
		DATE



CBV Series Specifications

Combination Ball Valve/Venturi

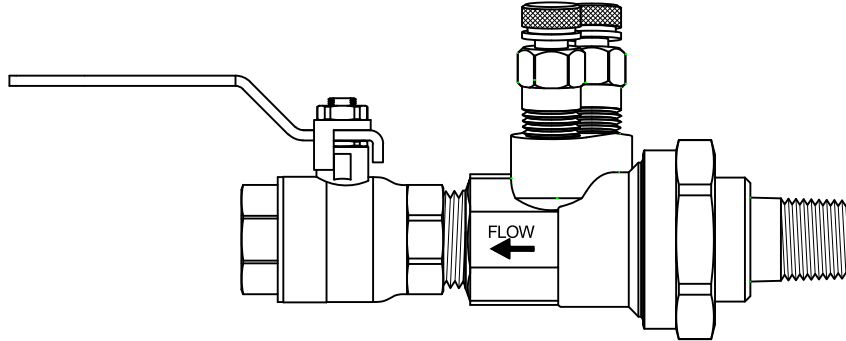

PRODUCT DESCRIPTION: The CBV flow balancing brass venturi provides highly accurate flow measurement capabilities. The efficient low loss venturi design provides effective flow balancing with minimal system pressure loss. The CBV includes a brass ball valve with memory stop, and a venturi with an integral union. The CBV comes standard with two pressure/temperature ports for instrument readings. The union side incorporates an o-ring for maximum sealing protection. The union connection options include FNPT, MNPT, SWT, and a variety of reductions.

NOTE: If the same size male, female, sweat, or a reducing male tail piece is used, no extra pipe diameter is required.

RECOMMENDED FLOW RANGES (GPM)					STANDARD MATERIAL SPECIFICATIONS	
Model	Size	Minimum	@ 100"	@ 200"		
CBV050L	½"	0.3	1.2	1.8	Venturi	Cast Brass ASTM B763-08A
CBV050H	½"	0.8	2.9	4.2	Ball Valve	Forged Brass ASTM B283-06
CBV075UL	¾"	0.3	1.2	1.8	O-ring	EPDM
CBV075L	¾"	0.8	2.9	4.2	Tail Piece	Brass ASTM B124-09, B228-06, or B763-08A
CBV075H	¾"	1.8	6.1	8.9	Union Nut	Brass ASTM B455
CBV100	1"	2.8	9.8	14.3	PT Seal	EPDM Dual Durometer Core
CBV125	1¼"	4.8	16.4	24.0	Handle	Chrome Plated Steel
CBV150	1½"	7.5	24.4	35.5	Memory Stop	302 Stainless Steel
CBV200	2"	12.0	40.8	69.3	Stem	Brass ASTM B124-09 - Blow-Out Proof
					Ball	Chrome Plated Brass
					Ball Seat	Teflon
					Packing Nut	Brass ASTM B124-09, B228-06, or B763-08A
					Packing Gland	Teflon
STANDARD OPERATING SPECIFICATIONS						
Maximum Working Pressure: 600 WOG / CWP			Maximum Operating Temperature: -22° F to 325° F			
Specification information is provided to assist and is given without obligation or warranty. The Company reserves the right to make changes in design, materials, and/or specifications without notice or liability.						

PRODUCT SPECIFICATIONS:

- Devices shall have a 15° regain chamber for optimal pressure regain and minimal permanent pressure drop
- Venturi tube shall be independent of the throttling valve
- Venturi tube shall include proper pipe diameters for optimal accuracy
- Valve shall be designed with memory stop to limit flow once balanced
- The Model CBV shall have an accuracy rating of:
 - ±1% between 10" W.C. and 70" W.C.
 - ±3% between 5" W.C. and 150" W.C.
 - ±5% less than 5" W.C. and over 150" W.C.



CBV Series Dimensions Combination Ball Valve/Venturi

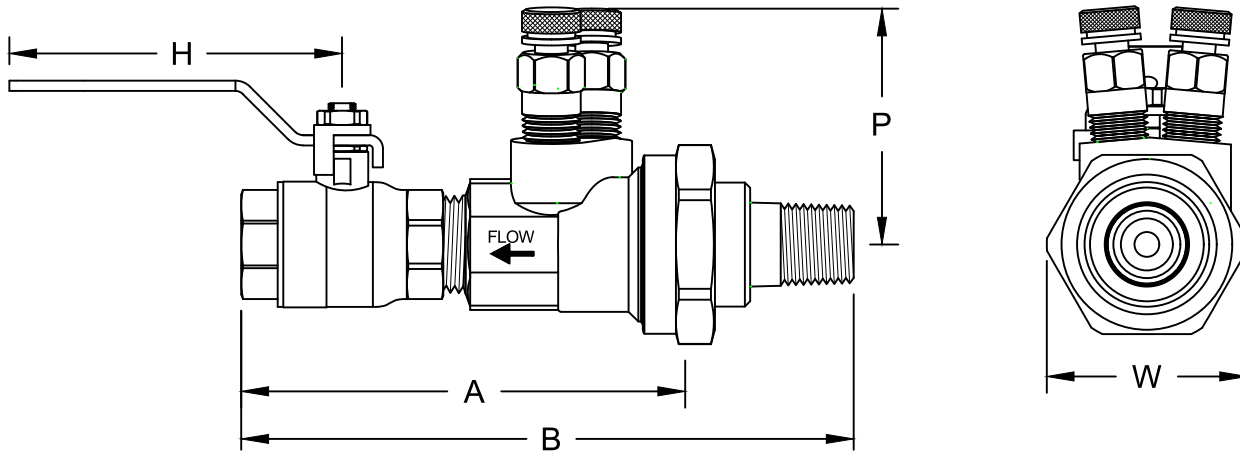

Model	Size	A		H	P	W	Cv **
		FPT	SWT				
CBV050L	½"	4.5	4.8	3.7	2.1	1.6	1.1
CBV050H	½"	4.5	4.8	3.7	2.1	1.6	3.8
CBV075UL*	¾"	4.7	5.2	3.8	2.1	1.6	1.1
CBV075L	¾"	4.7	5.2	3.8	2.1	1.8	2.3
CBV075H	¾"	4.7	5.2	3.8	2.1	1.8	8.0
CBV100	1"	5.1	5.7	5.0	2.2	2.1	13.4
CBV125	1¼"	5.8	6.5	5.0	2.4	2.8	25
CBV150	1½"	7.0	8.0	6.3	2.7	3.1	31
CBV200	2"	7.6	8.7	6.2	3.0	3.8	87

Size	Tail Piece	B	Weight	Size	Tail Piece	B	Weight
½" SWT	- M	6.2	1.4	½" FPT	- M	6.0	1.4
	½" - F	5.5	1.3		½" - F	5.1	1.3
	- S	5.5	1.3		- S	5.1	1.3
¾" SWT	- M	6.7	1.8	¾" FPT	- M	6.5	1.8
	½" - F	6.3	1.8		½" - F	5.8	1.8
	- S	6.0	1.7		- S	5.5	1.7
	- M	6.8	1.8		- M	6.5	1.8
	¾" - F	6.0	1.7		¾" - F	5.5	1.8
	- S	6.0	1.7		- S	5.5	1.7
1" SWT	½" - M	7.7	2.7	1" FPT	½" - M	7.1	2.7
	¾" - M	7.7	2.7		¾" - M	7.1	2.7
	- M	7.7	2.7		- M	7.0	2.7
	1" - F	6.7	2.5		1" - F	6.0	2.5
- S	6.7	2.5	- S	6.0	2.5		
1¼" SWT	½" - M	8.1	3.9	1¼" FPT	½" - M	7.5	3.9
	¾" - M	8.3	4.0		¾" - M	7.7	4.0
	1" - M	8.3	4.1		1" - M	7.7	4.1
	- M	8.5	4.2		- M	7.7	4.1
	1¼" - F	7.5	3.9		1¼" - F	6.7	3.8
	- S	7.5	3.7		- S	7.0	3.7
1½" SWT	¾" - M	9.7	5.6	1½" FPT	¾" - M	9.3	5.7
	1" - M	10.7	6.1		1" - M	9.5	6.0
	1¼" - M	10.7	6.2		1¼" - M	9.5	6.1
	- M	10.5	6.0		- M	9.5	6.0
	1½" - F	9.1	5.8		1½" - F	8.2	5.7
	- S	9.1	5.6		- S	8.2	5.6
2" SWT	1" - M	11.7	9.3	2" FPT	1" - M	10.5	9.1
	1¼" - M	11.7	8.9		1¼" - M	10.5	8.6
	1½" - M	11.7	8.9		1½" - M	10.5	8.7
	- M	11.7	9.0		- M	10.5	8.8
	2" - F	9.8	8.3		2" - F	8.7	8.1
	- S	10.1	8.0		- S	9.0	7.8

Note: Dimensions listed do not include ProPress or any other special fittings or adapters. All dimensions, weights, and materials are subject to minor variations. Consult with factory for confirmation of dimensions, weights, and material specifications.

* CBV075UL Tailpiece size is ½"

** Cv = Estimated with Union connection same as inlet, no reductions.

Note: Sweat size listed is nominal and will differ from the actual, measurable size. Not all available tailpiece connections are listed, please consult with factory for additional information.



CBV Series Submittal
Combination Ball Valve/Venturi

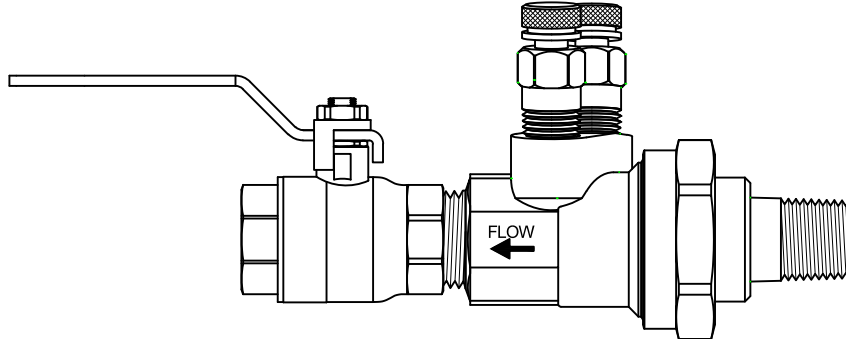

CBV - X - X - X - X - X - XX,

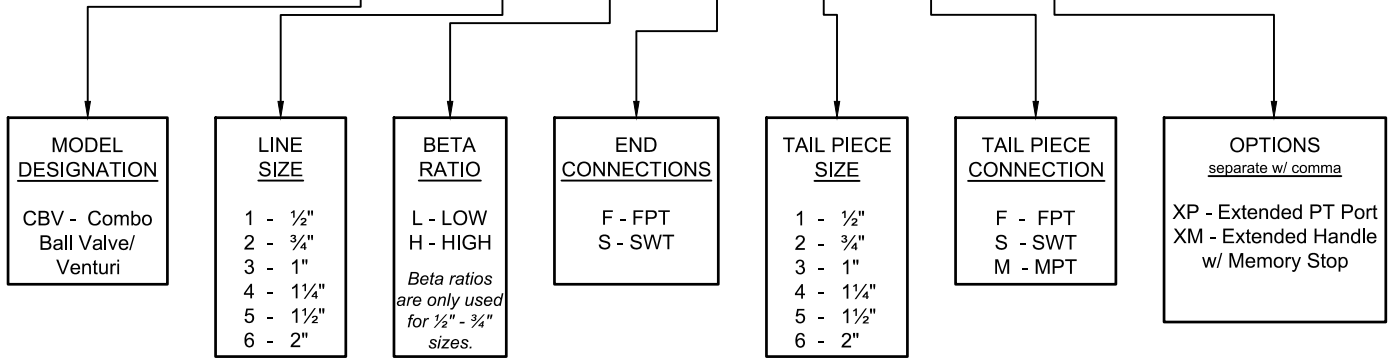

JOB NAME:		REPRESENTATIVE:	
ENGINEER:		REF/PO#:	DATE:
CONTRACTOR:		SUBMITTED BY:	DATE:
PART # (See table above)	TAGGING/JOB INFORMATION	GPM	QUANTITY



IVS Series Specifications

Integral Ball Valve/Wye Strainer/Union

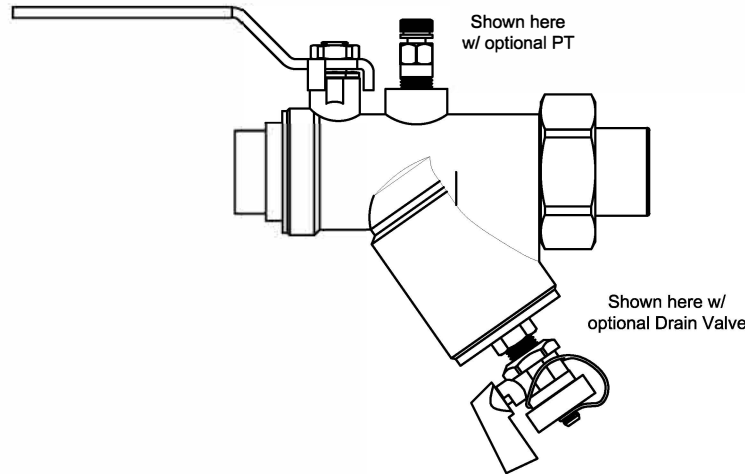

PRODUCT DESCRIPTION: The IVS is an integral ball valve, wye-strainer and union. The IVS uses a full-port ball valve for positive shut-off and offers two (2) predrilled ¼" taps for accessories to be installed. The strainer has a 20-mesh stainless steel screen to aid in debris removal. The strainer cap has a ¼" tap for a hose-end drain valve. The ball valve has a PTFE packing gland, brass packing nut, and blow-out proof double o-ring stem seal. The fixed end connections may be FNPT or SWT. The union side connections include MNPT, FNPT, SWT, and a variety of reductions.

STANDARD MATERIAL SPECIFICATIONS		PORT LOCATIONS
Body	Forged Brass ASTM B283-06, or cast Brass ASTM B763-08A	
O-Ring	EPDM	
Tail Piece	Brass ASTM B124-09, B228-06, or B763-08a	
Union Nut	Brass ASTM B455	
PT Seal	EPDM Dual Durometer Core	
Handle	Chrome Plated Steel	
Stem	Brass ASTM B124-09 - Blow-Out Proof	
Ball	Chrome Plated Brass - Full Port	
Ball Seat	Teflon	
Packing Gland	Teflon	
Packing Nut	Brass ASTM B124-09, B228-06, or B763-08a	
STANDARD OPERATING SPECIFICATIONS		
Maximum Working Pressure:	600 WOG / CWP	
Maximum Operating Temperature:	40° F to 250° F	
<p>Specification information is provided to assist and is given without obligation or warranty. The Company reserves the right to make changes in design, materials, and/or specifications without notice or liability.</p>		

PRODUCT SPECIFICATIONS:

- Device shall have a full port isolation valve
- Device shall have a 20 mesh accessible strainer sleeve
- Device shall have a blow down for debris removal
- Device shall have a functional by-pass
- The strainer screen shall have a minimum 8:1 ratio of total area against the internal pipe diameter



IVS Series Dimensions
Integral Ball Valve/Wye Strainer/Union

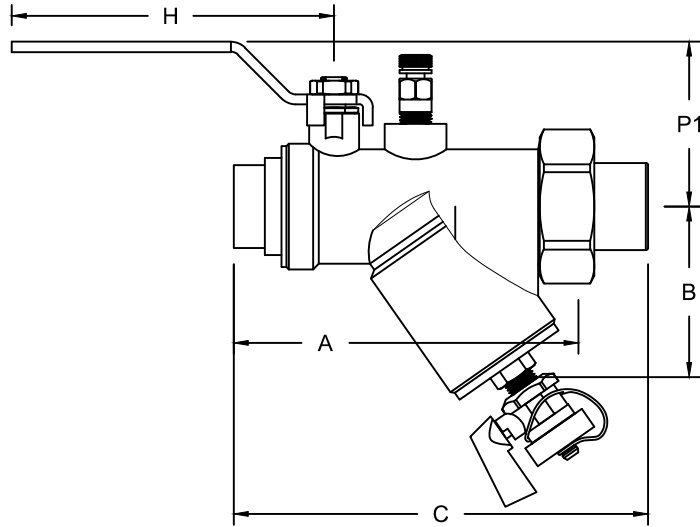

Model	Size	A	B	H	P1	* R
IVS1-SWT	1/2"	4.0	2.0	4.2	2.0	21:1
IVS2-SWT	3/4"	4.6	2.3	4.2	2.2	11:1
IVS3-SWT	1"	5.8	2.7	4.2	2.3	11:1
IVS1-FPT	1/2"	3.7	2.0	4.2	2.0	21:1
IVS2-FPT	3/4"	4.1	2.3	4.2	2.2	11:1
IVS3-FPT	1"	5.0	2.7	4.2	2.3	11:1

Note: Dimensions above do not include ProPress or any other special fittings or adapters. All dimensions, weights, and materials are subject to minor variations. Consult with factory for confirmation of dimensions, weights, and material specifications.

* R = Ratio of screen surface area to cross-sectional pipe diameter

Size	Tail Piece	C	Weight	Size	Tail Piece	C	Weight
1/2" SWT	- M	5.5	1.8	1/2" FPT	- M	5.2	1.6
	- F	4.6	1.5		- F	4.3	1.5
	- S	4.6	1.5		- S	4.3	1.5
3/4" SWT	- M	6.1	2.0	3/4" FPT	- M	5.6	2.1
	- F	5.7	2.1		- F	5.1	2.2
	- S	5.2	2.0		- S	4.7	2.0
	- M	6.2	2.1		- M	5.7	2.1
	- F	5.3	2.0		- F	4.8	2.0
	- S	5.5	2.0		- S	4.8	2.0
1" SWT	1/2" - M	7.8	3.0	1" FPT	1/2" - M	7.0	2.9
	3/4" - M	7.8	3.0		3/4" - M	7.0	2.9
	- S	6.6	2.7		- S	5.8	2.6
	- M	7.7	3.0		- M	7.0	2.9
	- F	6.7	2.8		- F	6.0	2.7
	- S	6.7	2.7		- S	6.0	2.7



IVS Series Submittal
Integral Ball Valve/Wye Strainer/Union

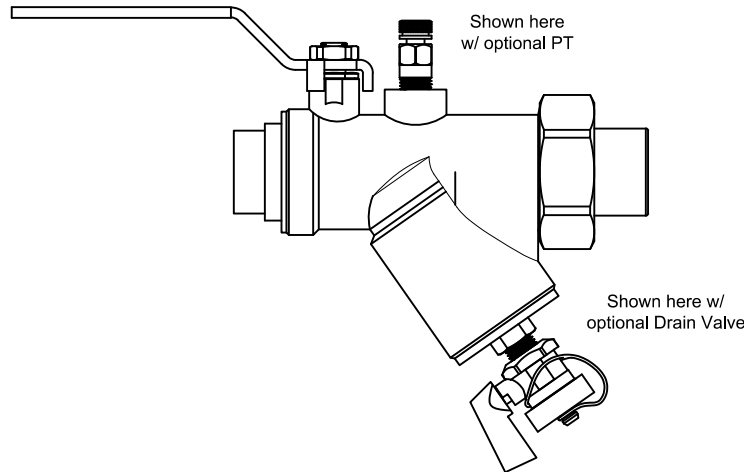

IVS - X - X - X - X - XX - XX

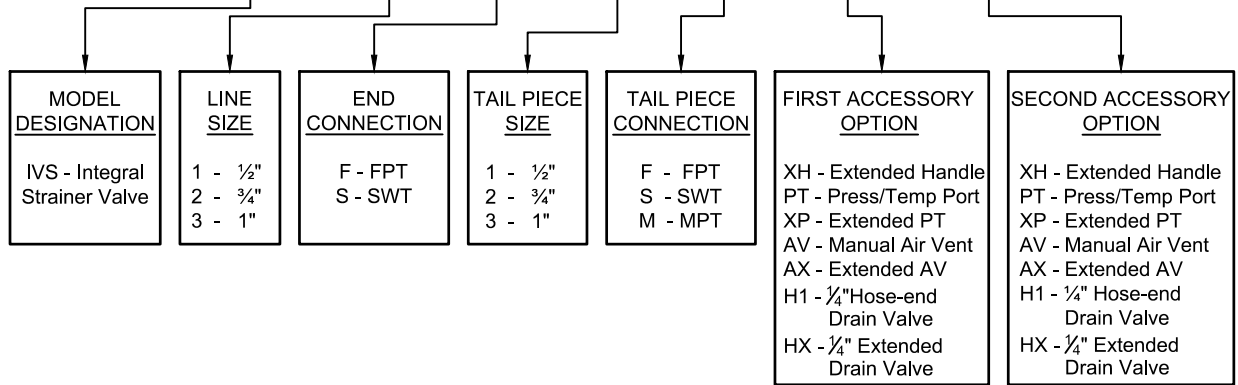

JOB NAME:		CUSTOMER:	
ENGINEER:		REF/PO#:	DATE:
CONTRACTOR:		SUBMITTED BY:	DATE:
PART # (See table above)	TAGGING/JOB INFORMATION		QUANTITY



HSS Series Specifications Stainless Steel Braided Hose

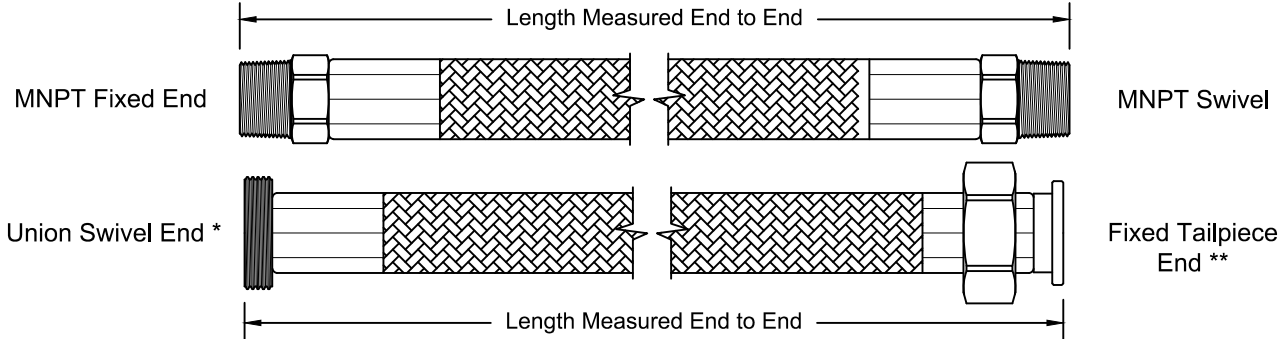

PRODUCT DESCRIPTION: The Model HSS is a stainless steel braided hose that is abrasion resistant. The HSS has a CPE inner tube with brass end connections and stainless steel ferrules for the ½" - 1" hose sizes, and an EPDM inner tube with stainless steel ferrules and plated steel end connections for the 1¼" - 2" hose sizes. The flexible hose eases installation and is designed to withstand high pressures and varying temperatures. The standard end connections are MNPT Fixed x MNPT Swivel for ½" to 2", and FNPT Swivel for ½" to 2". Other available end connection options are FNPT Swivel, Union Swivel *, and Fixed Tailpiece** and accessory union connections; available for the ½" to 2" hose sizes. The Model HSS is BUY AMERICAN COMPLIANT.

* The Swivel Union comes standard with an EPDM O-ring, tailpiece, and union nut which must be specified at the time of order. The swivel union easily converts line connection types and offers line size reductions. The tailpieces are available in FNPT, MNPT, and Sweat ends.

** The Fixed Tailpiece hose end connection is designed to connect directly to union ended coil kit components (AFLB, AFLD, AU, CBV, IBU, or IVY). The tailpiece end eliminates multiple connections.

PRODUCT SPECIFICATIONS	
Tube	CPE (Chlorinated Polyethylene) for ½" - 1" sizes - SAE J1019 EPDM (Ethylene Propylene Diene Monomer) for 1¼" - 2" sizes - SAE 20R1-D1
Reinforcement	304L Stainless Steel braid cover meets UL-94 requirements
Ferrules	Type 304L stainless Steel
End Fittings	½" - 1" I.D. - Brass 1¼" - 2" I.D. - Steel Plated
End Connections	Fixed MNPT, FNPT, Swivel MNPT, Swivel FNPT (½"-2"), Swivel Union (½" - 2"), Fixed Tailpiece (½"-2")
Temperature Ratings	-40°F to 257°F (-40°C to 125°C) NOTE HOSE IS NOT INTENDED FOR STEAM APPLICATIONS.
	Meets UL-94 Requirements Fire Retardant Material (CPE)
Specification information is provided to assist and is given without obligation or warranty. The Company reserves the right to make changes in design, materials, and/or specifications without notice.	

Size	Length	Working PSI	Bend Radius	** Cv
½"	12, 18, 24, 30, 36	500	5"	7
¾"	12, 18, 24, 30, 36	500	7"	20
1"	12, 18, 24, 30, 36	500	10"	43
1¼"	12, 18, 24, 30, 36	200	12"	76
1½"	12, 18, 24, 30, 36	200	15"	130
2"	12, 18, 24, 30, 36	200	20"	280

Length is measured End to End on all hose connection types.

** Cv listed in chart above is for a 24" length hose. The Cv is estimated and can vary according to installation.

PRO *Hydronic Specialties*

HSS Series Options Stainless Steel Braided Hose

Fixed MNPT

Swivel MNPT

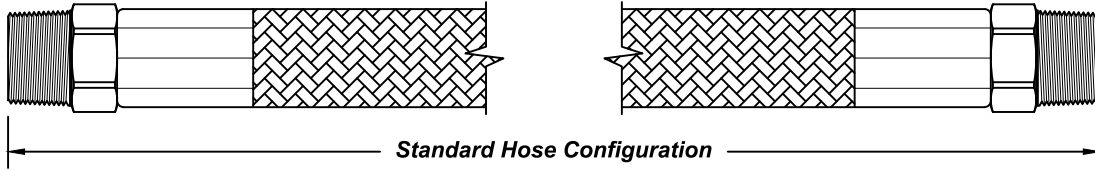

Additional End Connections

Swivel FNPT
Available in 1/2" thru 2"

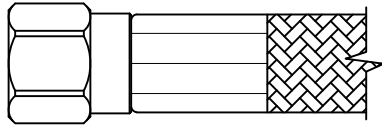

Swivel FJIC
Available in 1/2" thru 1"

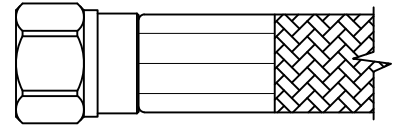

Swivel Union
Available in 1/2" thru 1"

The Swivel Union must have the tailpiece connection size and type specified at time of order. Tailpiece options include FPT, SWT, MPT, and a variety of reductions.

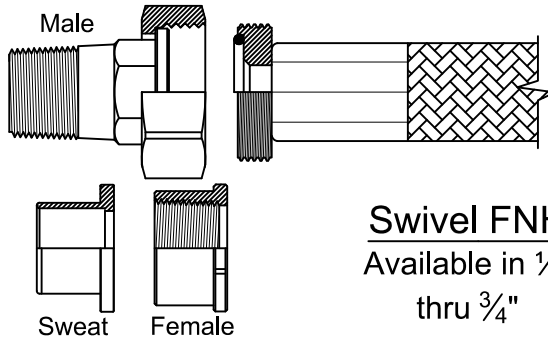

Swivel FNH
Available in 1/2" thru 3/4"

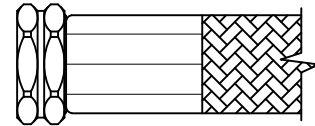

Fixed Tailpiece
Available in 1/2" thru 2"

The Fixed Tailpiece end connects directly to PRO Hydronic Specialties' union ended products.

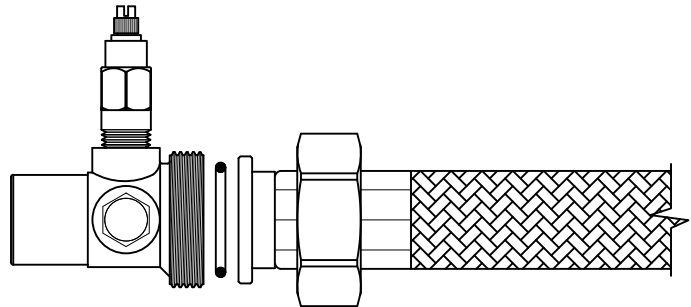

Swivel Accessory Union
Available in 1/2" thru 2"

The Swivel Accessory Union must have the tailpiece connection size and type specified at time of order.

Tailpiece options include FPT, SWT, MPT, and a variety of reductions.

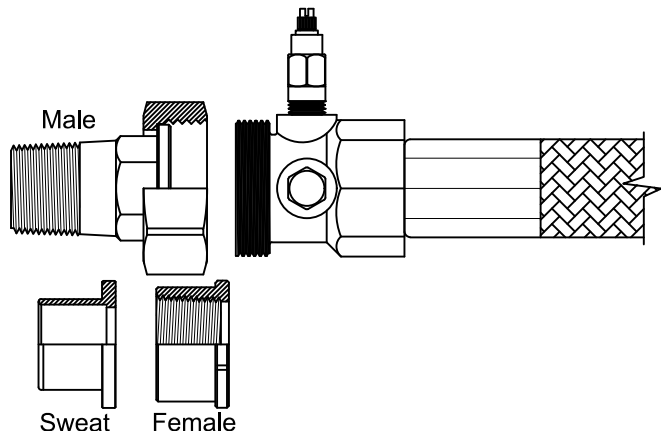



HSS Series Submittal
Stainless Steel Braided Hose

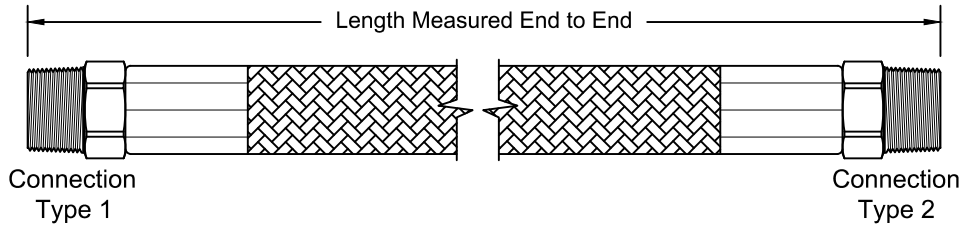

HSS - X - XX - X - X - X - X

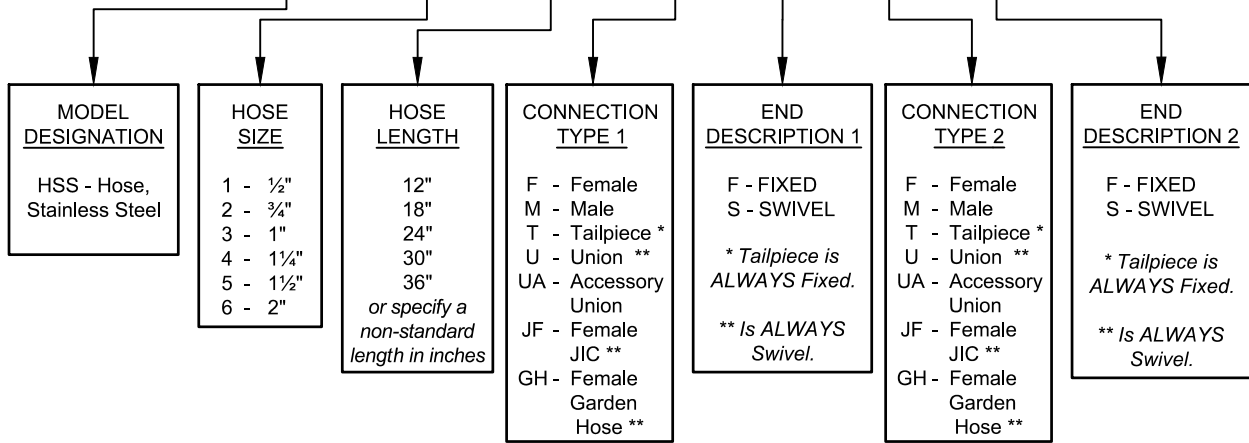

When ordering, at least one hose end connection must be a swivel.

JOB NAME:	REPRESENTATIVE:
ENGINEER:	REF/PO#:
CONTRACTOR:	SUBMITTED BY:
	DATE:
	DATE:
PART # (See table above)	QUANTITY