

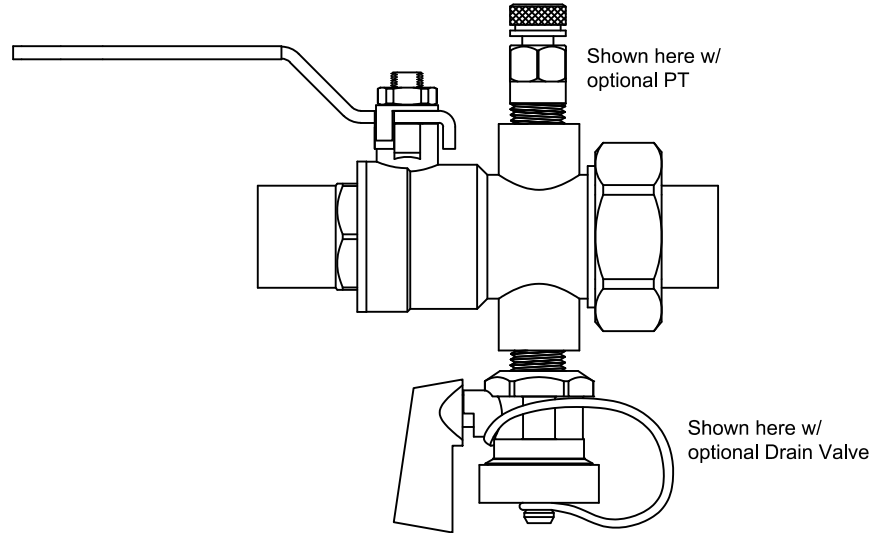

IBU Series Specifications Integral Ball Valve/Union



PRODUCT DESCRIPTION: The IBU is an integral ball valve and union. The IBU uses a full-port ball valve with a union ended brass body that provides two (2) 1/4" taps for accessories to be installed. All taps are plugged unless otherwise specified. Memory stops are available upon request. Fixed end connections may be SWT or FNPT. Union side connections available include MNPT, FNPT, and SWT, and a variety of reductions.

STANDARD MATERIAL SPECIFICATIONS	
Body	Forged Brass ASTM B283-06 or ASTM B763-08A
O-Ring	EPDM
Tail Piece	Brass ASTM B124-09, B228-06, or B763-08A
Union Nut	Brass ASTM B455
Handle	Chrome Plated Steel
Stem	Brass ASTM B124-09 - Blow-Out Proof
Ball	Chrome Plated Brass - Full Port
Ball Seat	Teflon
STANDARD OPERATING SPECIFICATIONS	
Maximum Working Pressure:	600 WOG / CWP
Maximum Operating Temperature:	250° F
<p>Specification information is provided to assist and is given without obligation or warranty. The Company reserves the right to make changes in design, materials, and/or specifications without notice or liability.</p>	

PRODUCT SPECIFICATIONS:

- Devices shall have a full port isolation valve to provide unrestricted flow
- Devices shall be designed to accept a memory stop
- Devices shall have a union end which allows for quick and convenient connection



IBU Series Dimensions Integral Ball Valve/Union

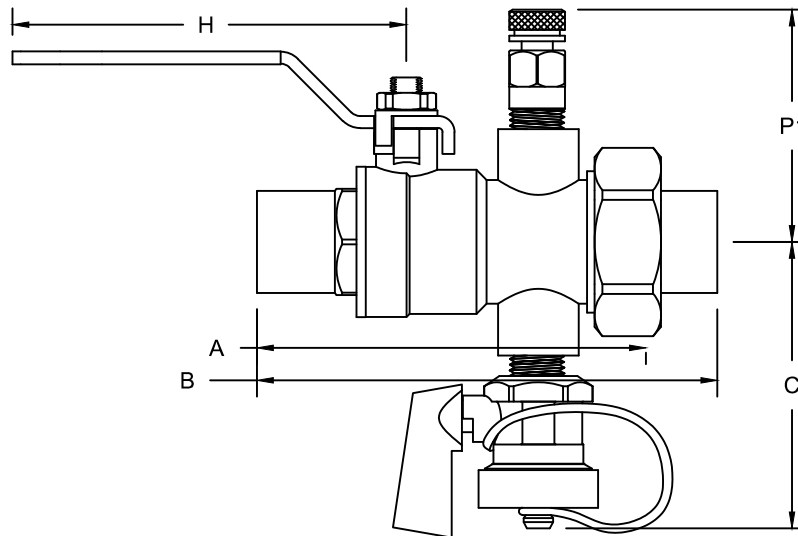

MODEL	SIZE	A	TAIL PIECE	B	Lbs	C	H	P1	* Cv
IBU1	½" - SWT	3.5	- M	5.1	1.2	2.5	3.8	2.0	19
			- F	4.2	1.2				
			- S	4.2	1.1				
	½" - FPT	3.2	- M	4.7	1.2				
IBU2	¾" - SWT	3.8	- M	5.3	1.5	2.7	3.8	2.2	35
			- F	4.9	1.6				
			- S	4.5	1.4				
			¾" - F	4.6	1.5				
			- M	5.5	1.5				
			- S	4.6	1.4				
	¾" - FPT	3.3	- M	4.8	1.5				
			- F	4.4	1.6				
			- S	4.1	1.4				
			- M	5.0	1.6				
			- F	4.1	1.5				
			- S	4.1	1.4				
IBU3	1" - SWT	4.1	½" - M	6.5	2.1	2.7	5.0	2.2	49
			¾" - M	6.5	2.1				
			- S	5.2	1.9				
			- M	6.5	2.2				
			1" - F	5.3	2.0				
			- S	5.4	1.9				
	1" - FPT	3.7	½" - M	5.7	2.1				
			¾" - M	5.7	2.1				
			- S	4.5	1.9				
			- M	5.7	2.2				
			1" - F	4.6	2.0				
			- S	4.7	1.9				

MODEL	SIZE	A	TAIL PIECE	B	Lbs	C	H	P1	* Cv
IBU4	1¼" - SWT	5.2	½" - M	7.0	3.6	3.2	4.6	2.5	102
			¾" - M	7.0	3.8				
			1" - M	7.0	3.8				
			- M	7.0	3.9				
			1¼" - F	6.0	3.6				
			- S	6.2	3.4				
	1¼" - FPT	4.5	½" - M	6.2	3.2				
			¾" - M	6.5	3.3				
			1" - M	6.5	3.4				
			- M	6.5	3.4				
			1¼" - F	5.6	3.1				
			- S	5.7	3.0				
IBU5	1½" - SWT	5.8	¾" - M	7.5	4.6	3.5	5.5	2.7	266
			1" - M	8.0	4.9				
			1¼" - M	8.1	5.0				
			- M	8.1	4.9				
			1½" - F	7.0	4.6				
			- S	7.0	4.4				
	1½" - FPT	5.2	¾" - M	7.1	4.4				
			1" - M	7.5	4.8				
			1¼" - M	7.5	4.8				
			- M	7.5	4.7				
			1½" - F	6.5	4.4				
			- S	6.3	4.2				
IBU6	2" - SWT	7.1	1" - M	10.1	8.0	3.5	6.3	3.0	297
			1¼" - M	10.0	7.7				
			1½" - M	10.0	7.7				
			- M	10.0	7.7				
			2" - F	8.2	7.1				
			- S	8.5	6.7				
	2" - FPT	6.0	1" - M	8.9	7.8				
			1¼" - M	8.9	7.4				
			1½" - M	8.9	7.4				
			- M	8.9	7.4				
			2" - F	7.0	6.8				
			- S	7.2	6.4				

Note: Dimensions listed do not include ProPress or any other special fittings or adapters. All dimensions and materials are subject to minor variations. Consult with factory for confirmation of dimensions and material specifications at the time of order. Sweat size listed is nominal and will differ from the actual, measurable size.

* Cv = Estimated with union connection same as inlet, no reductions.



IBU Series Submittal
Integral Ball Valve/Union

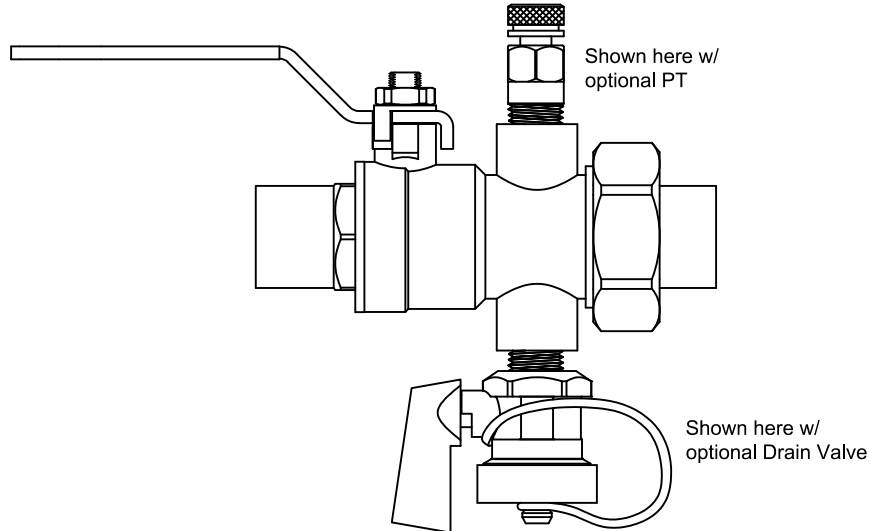

IBU - X - X - X - X - XX - XX

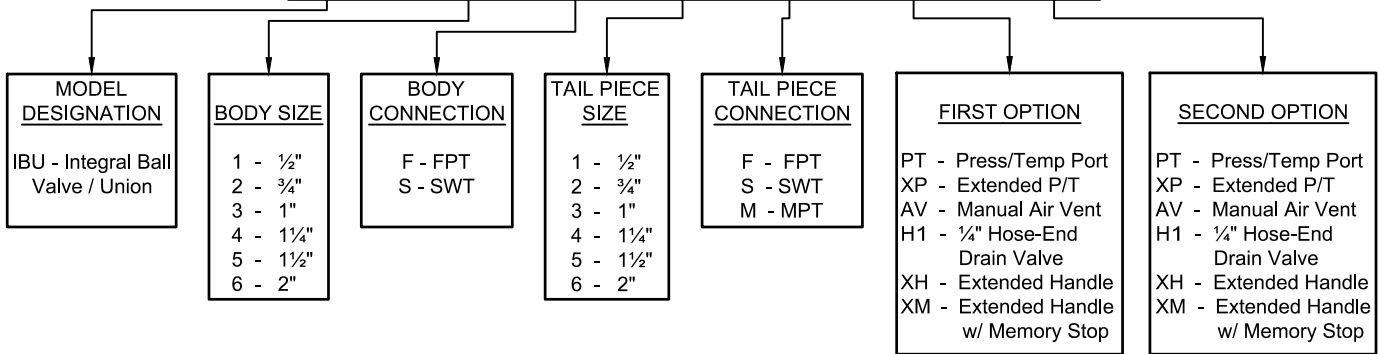

JOB NAME:	CUSTOMER:	DATE:
ENGINEER:	REF/PO#:	DATE:
CONTRACTOR:	SUBMITTED BY:	DATE:
PART # (See table above)	TAGGING/JOB INFORMATION	QUANTITY



IVY Series Specifications

Integral Ball Valve/Wye Strainer/Union

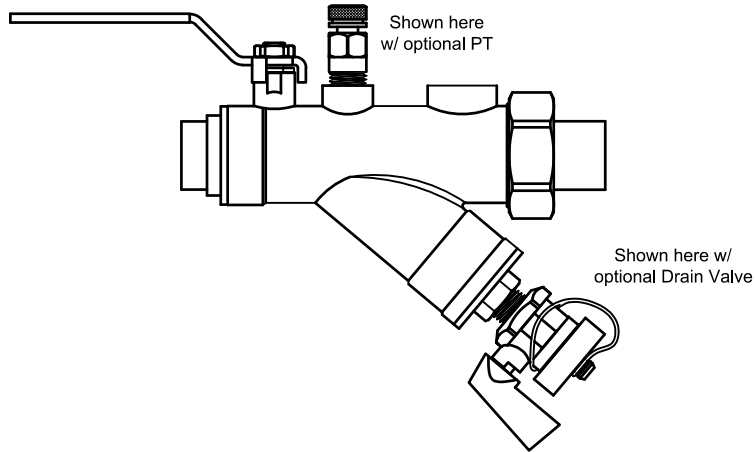

PRODUCT DESCRIPTION: The IVY is an integral ball valve, wye-strainer and union. The IVY uses a full-port ball valve for positive shut-off and offers two (2) predrilled ¼" taps for accessories to be installed. A ¼" standard port and by-pass tap are provided at the forward 12:00 position. The bypass port comes tapped and plugged for 2-way control valve configurations. The bypass port remains open on 3-way control valve configurations to install a bypass valve. (See *IVY Series Dimensions* page for *bypass valve sizes*.) An additional side port is available for factory drilling and tapping a ¼" port. The strainer has a 20-mesh stainless steel screen to aid in debris removal. The strainer cap has a ¼" tap for a hose-end drain valve. The ball valve has a PTFE packing gland, brass packing nut, and blow-out proof double o-ring stem seal. The fixed end connections may be FNPT or SWT. The union side connections include MNPT, FNPT, SWT, and a variety of reductions.

STANDARD MATERIAL SPECIFICATIONS		PORT LOCATIONS
Body	Forged Brass ASTM B283-06, or cast Brass ASTM B763-08A	
O-Ring	EPDM	
Tail Piece	Brass ASTM B124-09, B228-06, or B763-08a	
Union Nut	Brass ASTM B455	
PT Seal	EPDM Dual Durometer Core	
Handle	Chrome Plated Steel	
Stem	Brass ASTM B124-09 - Blow-Out Proof	
Ball	Chrome Plated Brass - Full Port	
Ball Seat	Teflon	
Packing Gland	Teflon	
Packing Nut	Brass ASTM B124-09, B228-06, or B763-08a	
STANDARD OPERATING SPECIFICATIONS		
Maximum Working Pressure:	600 WOG / CWP	
Maximum Operating Temperature:	-22° F to 325° F	
<p>Specification information is provided to assist and is given without obligation or warranty. The Company reserves the right to make changes in design, materials, and/or specifications without notice or liability.</p>		

PRODUCT SPECIFICATIONS:

- Device shall have a full port isolation valve
- Device shall have a 20 mesh accessible strainer sleeve(0standard) or a 40 mesh accessible strainer sleeve (optional)
- Device shall have a blow down for debris removal
- Device shall have a functional by-pass
- The strainer screen shall have a minimum 8:1 ratio of total area against the internal pipe diameter



IVY Series Dimensions Integral Ball Valve/Wye Strainer/Union

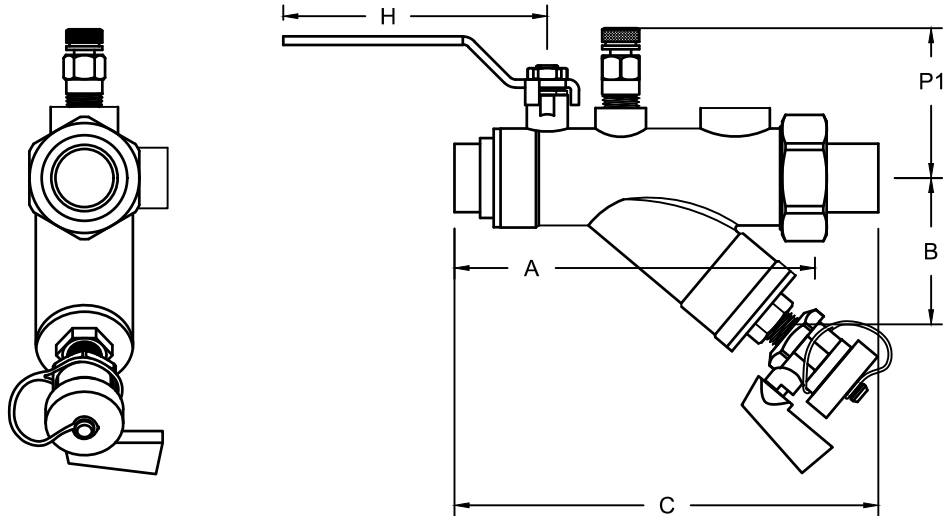

Model	Size	Bypass Size	A	B	H	P1	* R	** Cv
IVY1-SWT	½"	½"	4.4	2.3	4.1	2.0	11 : 1	8
IVY2-SWT	¾"	½"	5.4	2.2	3.8	2.1	8 : 1	9
IVY3-SWT	1"	½"	6.1	2.7	3.9	2.3	11 : 1	20
IVY4-SWT	1 ¼"	¾"	7.0	3.2	3.8	2.7	9 : 1	23
IVY5-SWT	1 ½"	¾"	8.6	3.2	6.3	3.0	13 : 1	44
IVY6-SWT	2"	1"	9.2	3.5	6.5	3.1	9 : 1	46
IVY1-FPT	½"	½"	4.2	2.3	4.1	2.0	11 : 1	7
IVY2-FPT	¾"	½"	4.9	2.2	3.8	2.1	8 : 1	8
IVY3-FPT	1"	½"	5.4	2.7	3.9	2.3	11 : 1	19
IVY4-FPT	1 ¼"	¾"	6.3	3.2	3.8	2.7	9 : 1	21
IVY5-FPT	1 ½"	¾"	7.5	3.2	6.3	3.0	13 : 1	45
IVY6-FPT	2"	1"	8.1	3.5	6.5	3.1	9 : 1	47

Size	Tail Piece	C	Weight	Size	Tail Piece	C	Weight
½" SWT	- M	6.0	1.8	½" FPT	- M	6.5	1.8
	- F	5.1	1.8		- F	4.8	1.8
	- S	5.1	1.8		- S	4.8	1.8
¾" SWT	- M	7.0	2.2	¾" FPT	- M	6.5	2.5
	- F	6.3	2.3		- F	6.0	2.5
	- S	6.1	2.2		- S	5.7	2.1
	- M	7.0	2.3		- M	6.5	2.3
	- F	6.1	2.2		- F	5.7	2.2
	- S	6.2	2.2		- S	5.7	2.2
1" SWT	- M	8.1	3.2	1" FPT	- M	7.2	3.2
	- F	8.1	3.7		- F	7.2	3.2
	- S	7.0	3.4		- S	6.1	3.0
	- M	8.1	3.5		- M	7.2	3.3
	- F	7.1	3.1		- F	6.2	3.1
	- S	7.1	3.0		- S	6.2	3.1
1 ¼" SWT	- M	9.0	5.0	1 ¼" FPT	- M	8.2	5.0
	- F	9.0	5.0		- F	8.2	5.1
	- S	8.2	4.6		- S	7.7	4.7
	- M	9.0	5.1		- M	8.2	5.1
	- F	8.0	4.8		- F	7.3	4.8
	- S	8.1	4.7		- S	7.5	4.7
1 ½" SWT	- M	11.0	7.6	1 ½" FPT	- M	10.1	7.4
	- F	11.0	7.7		- F	10.0	7.6
	- S	10.0	7.1		- S	9.0	7.0
	- M	11.0	7.6		- M	10.1	7.4
	- F	9.8	7.3		- F	9.0	7.2
	- S	9.7	7.1		- S	8.8	7.0
2" SWT	- M	12.2	10.0	2" FPT	- M	11.1	9.7
	- F	12.2	8.6		- F	11.1	9.7
	- S	11.0	9.0		- S	9.7	8.8
	- M	12.2	10.0		- M	11.1	9.8
	- F	10.5	9.4		- F	9.2	9.1
	- S	10.7	9.0		- S	9.5	8.8

Note: Dimensions above do not include ProPress or any other special fittings or adapters. All dimensions, weights, and materials are subject to minor variations. Consult with factory for confirmation of dimensions, weights, and material specifications.

* R = Ratio of screen surface area to cross-sectional pipe diameter

** Cv = Estimated with Union Connection same as inlet, no reductions.

Note: Sweat size listed is nominal and will differ from the actual, measurable size.



IVY Series Submittal
Integral Ball Valve/Wye Strainer/Union

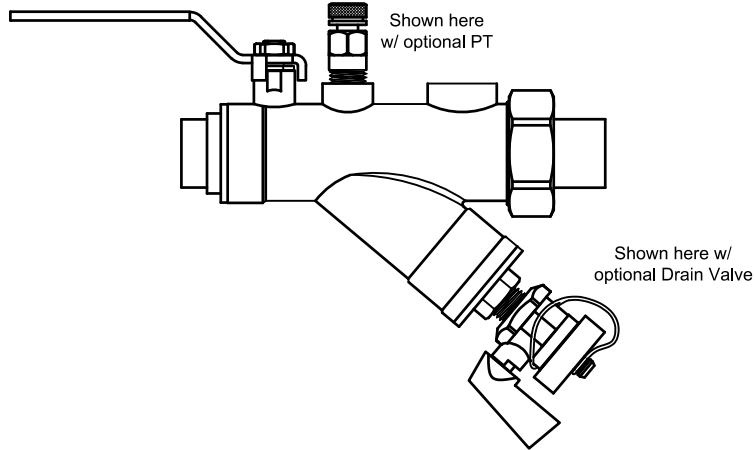

IVY - X - X - X - X - XX - XX - X

MODEL DESIGNATION	LINE SIZE	END CONNECTION	TAIL PIECE SIZE	TAIL PIECE CONNECTION	FIRST ACCESSORY OPTION	SECOND ACCESSORY OPTION	BYPASS OPTION
IVY - Integral Strainer Valve	1 - 1/2" 2 - 3/4" 3 - 1" 4 - 1 1/4" 5 - 1 1/2" 6 - 2"	F - FPT S - SWT	1 - 1/2" 2 - 3/4" 3 - 1" 4 - 1 1/4" 5 - 1 1/2" 6 - 2"	F - FPT S - SWT M - MPT	XH - Extended Handle PT - Press/Temp Port XP - Extended PT AV - Manual Air Vent AX - Extended AV H1 - 1/4" Hose-end Drain Valve	XH - Extended Handle PT - Press/Temp Port XP - Extended PT AV - Manual Air Vent AX - Extended AV H1 - 1/4" Hose-end Drain Valve	B = Bypass <i>Bypass tap size provided on IVY Dimensions Form : SUBIVY2</i>

JOB NAME:		CUSTOMER:	
ENGINEER:		REF/PO#:	DATE:
CONTRACTOR:		SUBMITTED BY:	DATE:
PART # (See table above)	TAGGING/JOB INFORMATION		QUANTITY



AU Series Specifications Accessory Union

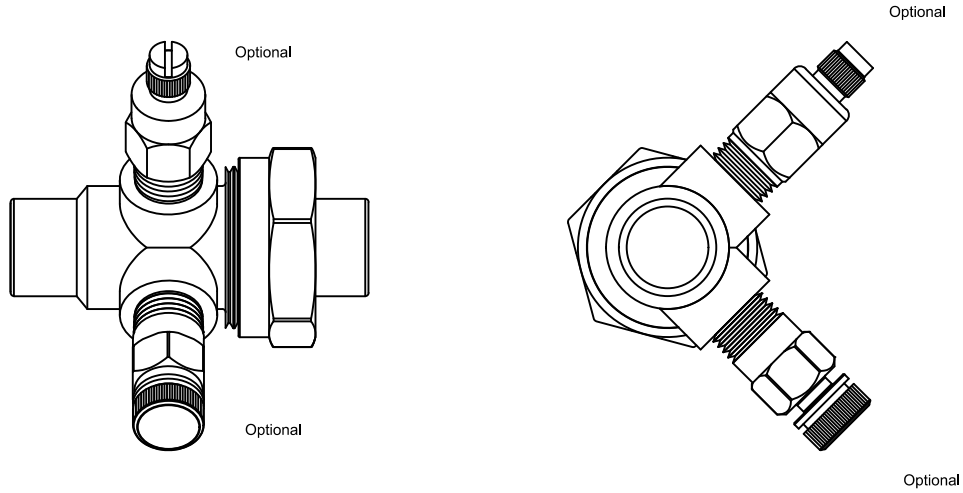

Product Description: The AU brass accessory union provides for component isolation. Port section contains two 1/4" ports that come predrilled from the factory and are positioned 90° apart. The union side incorporates an o-ring for maximum sealing protection. Accessory union comes standard with 1/4" plugs installed in the ports. Union side and port side connections available in NPTM, NPTF, and SWT. Rated at 600 WOG @ -22°F to 325°F.

STANDARD MATERIAL SPECIFICATIONS	
Accessory Union	Forged Brass ASTM B283-06
O-Ring	EPDM
Tail Piece	Brass ASTM B124-09, B228-06, or B763-08A
<p>Specification information is provided to assist and is given without obligation or warranty. The Company reserves the right to make changes in design, materials, and/or specifications without notice or liability.</p>	

PRODUCT SPECIFICATIONS:

- 1/4" ports shall be located 90° distal on a rotational axis
- Integrated ports shall provide functionality for numerous options



AU Series Dimensions Accessory Union

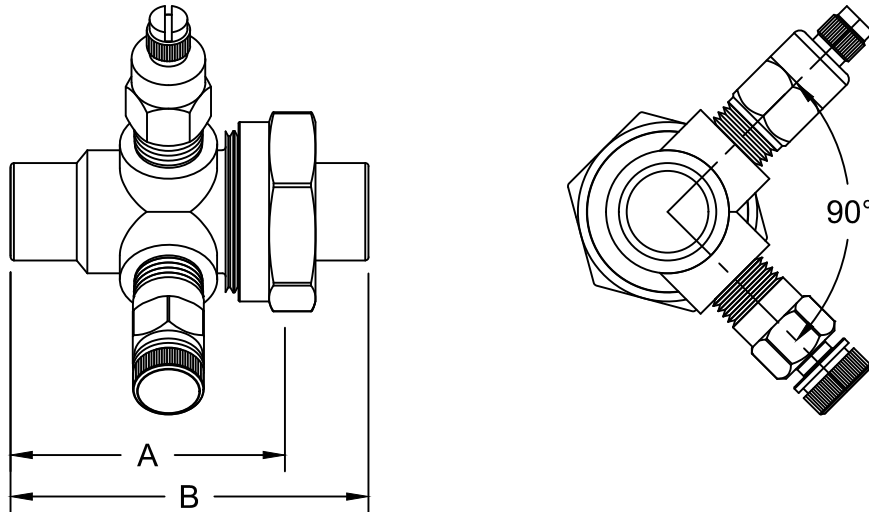

MODEL	SIZE	A	LENGTH "B" / WEIGHT OF PRO-AU AND TAIL PIECE CONNECTION											
			$\frac{1}{2}$ " M	lbs	$\frac{1}{2}$ " S	lbs	$\frac{1}{2}$ " F	lbs	$\frac{3}{4}$ " M	lbs	$\frac{3}{4}$ " S	lbs	$\frac{3}{4}$ " F	lbs
AU1M	$\frac{1}{2}$ "	2.7	4.2	0.6	3.3	0.6	3.3	0.6						
AU1S		2.1	3.7	0.5	2.8	0.4	2.8	0.5						
AU1F		2.0	3.6	0.6	2.7	0.5	2.7	0.5						
AU2M	$\frac{3}{4}$ "	2.5	4.0	0.7	3.2	0.6	3.6	0.8	4.2	0.7	3.2	0.6	3.3	0.7
AU2S		2.1	3.7	0.6	2.9	0.5	3.3	0.6	3.8	0.6	2.9	0.5	2.9	0.6
AU2F		2.1	3.6	0.7	2.8	0.6	3.2	0.8	3.8	0.7	2.8	0.6	2.9	0.7
AU3M	1"	2.6	4.6	1.1	4.6	1.1	3.4	0.9	4.6	1.2	3.6	0.9	3.5	1.0
AU3S		2.4	4.5	1.0	4.5	1.0	3.3	0.7	4.5	1.0	3.5	0.8	3.4	0.8
AU3F		2.1	4.1	1.0	4.1	1.1	3.0	0.8	4.1	1.1	3.3	0.9	3.1	0.9
AU4M	1 $\frac{1}{4}$ "	3.0	4.7	1.7	5.0	1.8	5.0	1.9	5.0	1.9	4.1	1.5	4.0	1.6
AU4S		3.0	4.7	1.5	4.9	1.7	4.9	1.7	5.0	1.8	4.1	1.4	4.0	1.5
AU4F		2.3	4.1	1.6	4.3	1.8	4.3	1.8	4.4	1.9	3.4	1.5	3.3	1.6
AU5M	1 $\frac{1}{2}$ "	3.0	4.9	2.3	5.5	2.6	5.5	2.7	5.5	2.5	4.2	2.1	4.3	2.3
AU5S		3.0	4.9	2.2	5.5	2.6	5.5	2.6	5.5	2.5	4.2	2.0	4.2	2.2
AU5F		2.7	4.6	2.3	5.1	2.7	5.1	2.7	5.1	2.6	3.9	2.2	3.9	2.3
AU6M	2"	3.4	6.2	4.3	6.2	4.0	6.2	4.0	6.2	4.1	4.8	3.1	4.6	3.4
AU6S		2.8	5.8	4.0	5.8	3.6	5.8	3.6	5.8	3.7	4.2	2.7	4.0	3.0
AU6F		2.8	5.8	4.5	5.7	4.2	5.7	4.1	5.8	4.2	4.2	3.2	3.9	3.5

Note: Dimensions listed above do not include ProPress or any other special fittings or adapters. All dimensions, weights, and materials are subject to minor variations. Consult with factory for confirmation of dimensions, weights, and material specifications. Sweat size listed is nominal and will differ from the actual, measurable size.



AU Series Submittal
Accessory Union

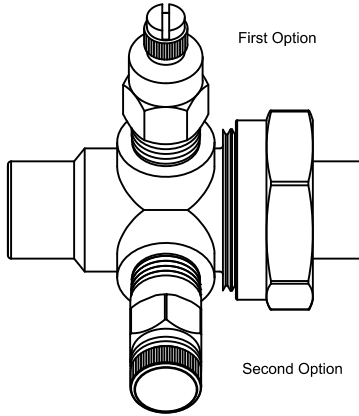

AU - X - X - X - X - XX - XX

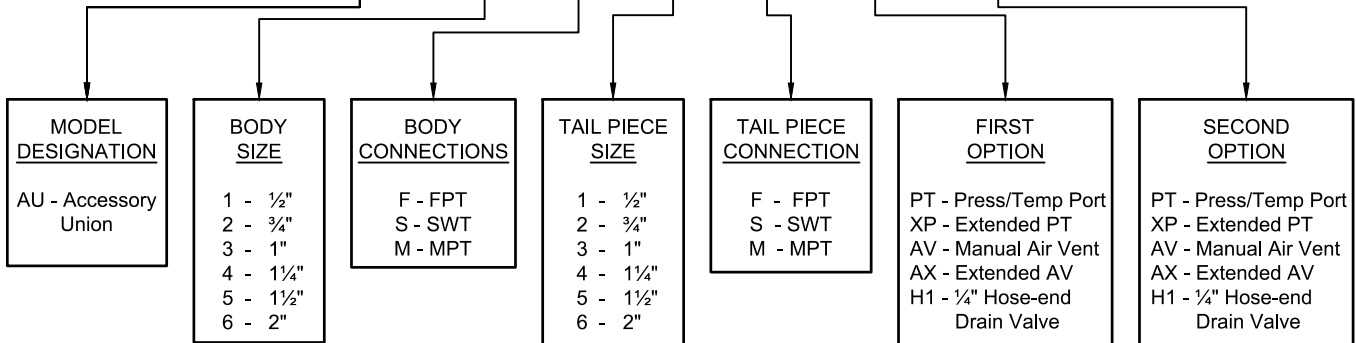

JOB NAME: ENGINEER: CONTRACTOR:	REPRESENTATIVE: REF/PO#: SUBMITTED BY:	
DATE: DATE:		
PART # (See table above)	TAGGING/JOB INFORMATION	QUANTITY