

PRO Hydronic Specialties

Manual Balancing 3-Way Kit - V3BBH Submittal

	#	Size	Connection Type
Runout	1		
Coil	2		
TCV	3		MPT
Bypass Out	4		
Bypass In	5		
<i>Services provided for additional fee:</i>			
Extended Components	<input type="checkbox"/> Yes	<input type="checkbox"/> No	
Factory Mounted TCV	<input type="checkbox"/> Yes	<input type="checkbox"/> No	
Stainless Steel Trim	<input type="checkbox"/> Yes	<input type="checkbox"/> No	
Factory Mounted Hoses	<input type="checkbox"/> Yes	<input type="checkbox"/> No	
Bag N Tag	<input type="checkbox"/> Yes	<input type="checkbox"/> No	

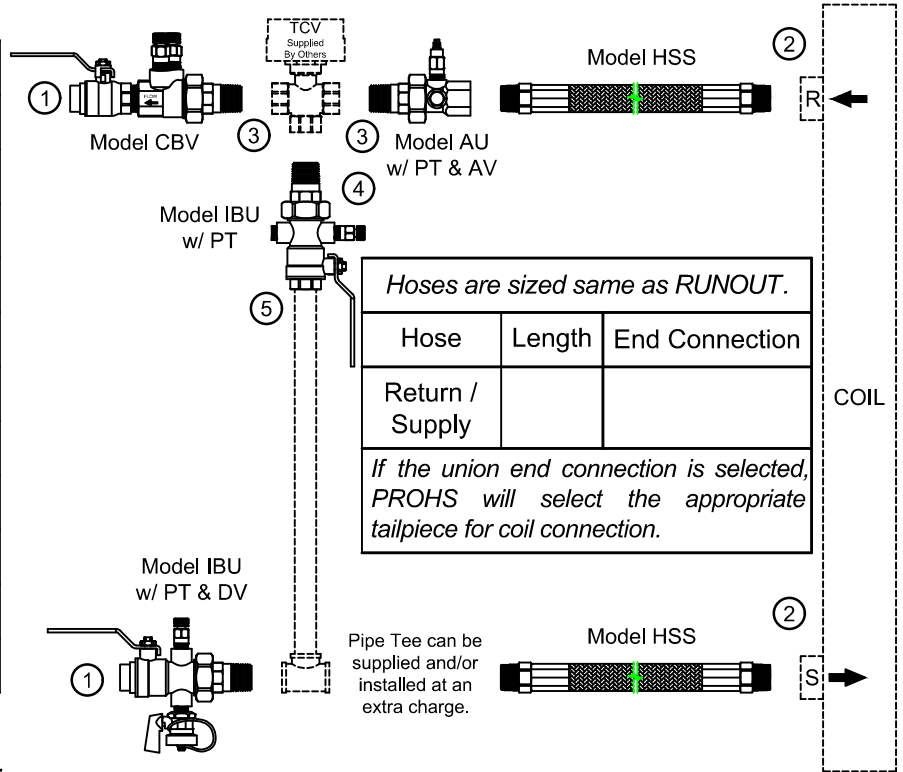

* 3/8" Coil Size available in SWT ONLY.
 ** ProPress fittings supplied for additional fee.

PRODUCT DESCRIPTION: The Manual Balancing Valve Kit is a packaged and partially preassembled grouping of components required to complete installation of a terminal unit. Temperature control valves, piping, and coils are supplied "by others". Mounting and testing of the customer supplied TCV is available at an additional charge.

QUANTITY	GPM	TAGGING INFORMATION

JOB NAME	REPRESENTATIVE		
ENGINEER	REF/PO#	DATE	
CONTRACTOR	SUBMITTED BY	DATE	