

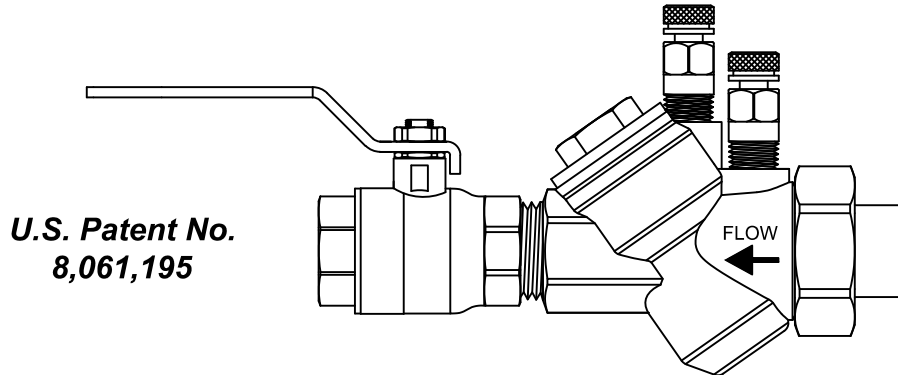

## AFLB Series Specifications

### Automatic Pressure Independent Flow Limiter w/ Ball Valve

- A: AFLB - ½" - 1" Low
- B: AFLB - 1" High - 1½" Low
- C: AFLB - 1½" High - 2"



**PRODUCT DESCRIPTION:** The AFLB is an Automatic Pressure Independent Flow Limiting device, male ended by union with a brass ball valve attached, rated at 600 WOG / CWP @ 250° F. The AFLB is supplied with a stainless steel flow limiting cartridge that can be removed for cartridge exchange, if necessary. The AFLB comes standard with two pressure/temperature ports and a hanging identification tag. The ball valve end, or run-out side, is available in FNPT or SWT. The union side connections available include MNPT, FNPT, SWT, and a variety of reductions.

STANDARD MATERIAL SPECIFICATIONS		STANDARD OPERATING SPECIFICATIONS	
Body	Forged Brass ASTM B283-06 or Cast Brass ASTM B763-08A	Control Range:	2 psi - 60+ psi
O-Ring	EPDM	Accuracy:	±5%
Tail Piece, Packing Nut	Brass ASTM B124-09, B228-06, or B763-08A	Max Working Pressure:	600 WOG / CWP
Union Nut	Brass ASTM B455	Max Operating Temperature:	40°F to 250°F
Flow Cartridge	ASTM A582 Type 303 Stainless Steel	Start-Up Head Loss:	5 Feet of H <sub>2</sub> O
Diaphragm	EPDM	Specification information is provided to assist and is given without obligation or warranty. The Company reserves the right to make changes in design, materials, and/or specifications without notice or liability.	
Spring	302 Stainless Steel		
PT Port	EPDM Dual Durometer Core		
Ball Valve	Forged Brass ASTM B283-06		
Stem	Brass ASTM B124-09 - Blow-Out Proof		
Ball	Chrome Plated Brass		
Ball Seat, Packing Gland	Teflon		
Handle	Chrome Plated Steel w/ Vinyl Cover		

Valve Size	FLOW RATES (GPM) * CONTROL RANGE 2 - 60+ PSID **																									
	A	B	C	D	E	F	G	H	I	J	K	L	M	N	O	P	Q	R	S	T	U	V	W	X	Y	Z
A ½" - 1" L	.33	.50	.75	1	1.25	1.5	1.75	2	2.25	2.5	2.75	3	3.5	4	4.5	5	5.5	6	6.5	7	7.5	8	9	10	11	12
B 1" H - 1½" L	5	5.5	6	6.5	7	8	9	10	12	13	14	15	16	18	20	22	24	26	28	30	32	34	36	38	40	42
C 1½" H - 2"	15	20	25	30	35	40	45	50	55	60	65	70	75	80	85	90	95	100	110	120	130	140	150	160	170	180

\* Custom flow rates can be calibrated at the factory for an additional charge.  
 Unless confirmed as special, flow rates will default to standard flow rate.

#### PRODUCT SPECIFICATIONS:

- The Automatic Flow Limiter with Ball Valve (AFLB) shall have flow measurement capability
- The AFLB shall have a static orifice to control flow
- The AFLB Cartridge shall be permanently marked with the letter that corresponds to the factory preset GPM
- All flow cartridge wear surfaces shall be stainless steel
- The AFLB shall have a 2 PSID start up rating
- The AFLB Cartridge shall have a large operational differential range
- The AFLB Cartridge shall provide continual flow at differential pressures above design limits
- The AFLB Cartridge shall be removable for cleaning or exchange if required



### AFLB Series Dimensions

### Automatic Pressure Independent Flow Limiter w/ Ball Valve

A: AFLB - 1/2" - 1" L

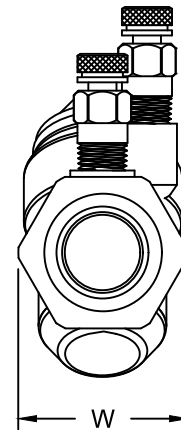
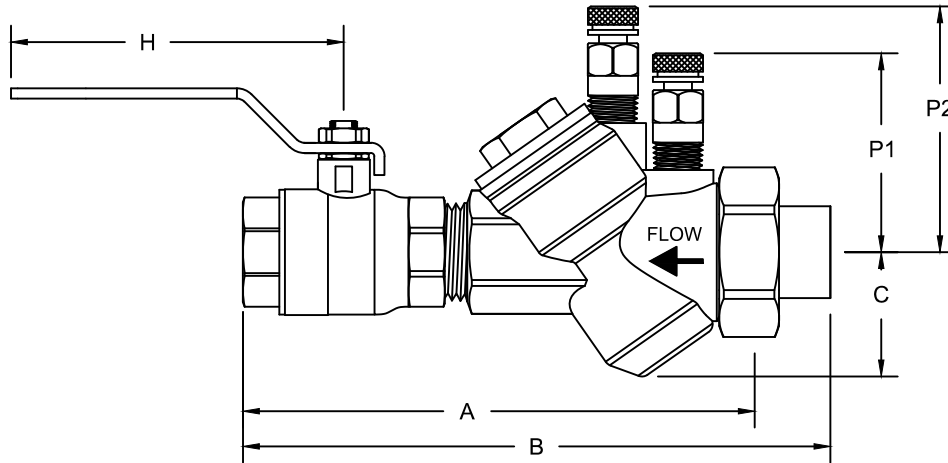

BALL VALVE SIZE AND TYPE	A	TAIL PIECE	B	WEIGHT (lbs)	C	H	P1	P2	W
1/2" SWT	5.7	- M	7.3	1.8	1.3	3.7	2.3	2.8	1.7
		- F	6.4	1.8					
		- S	6.4	1.7					
1/2" FPT	5.4	- M	7.0	1.8	1.3	3.7	2.3	2.8	1.7
		- F	6.0	1.8					
		- S	6.0	1.7					
3/4" SWT	6.6	- M	8.1	2.4	1.4	3.8	2.0	2.6	1.8
		1/2" - F	7.3	2.4					
		- S	7.3	2.4					
		- M	8.3	2.5					
		3/4" - F	7.2	2.4					
		- S	7.2	2.4					
3/4" FPT	6.1	- M	7.5	2.4	1.4	3.8	2.0	2.6	1.8
		1/2" - F	7.2	2.5					
		- S	6.8	2.4					
		- M	7.8	2.5					
		3/4" - F	7.0	2.4					
		- S	6.8	2.4					
1" SWT	7.3	1/2" - M	9.5	3.5	1.2	5.0	2.0	2.5	2.1
		3/4" - M	9.5	3.5					
		- S	8.2	3.3					
		- M	9.5	3.6					
		1" - F	8.5	3.4					
		- S	8.5	3.3					
1" FPT	6.7	1/2" - M	8.7	3.5	1.2	5.0	2.0	2.5	2.1
		3/4" - M	8.7	3.5					
		- S	7.5	3.3					
		- M	8.7	3.6					
		1" - F	7.6	3.4					
		- S	7.6	3.3					

Note: Dimensions listed above do not include ProPress or any other special fittings or adapters. All dimensions, weights, and materials are subject to minor variations. Consult with factory for confirmation of dimensions and material specifications. Sweat size listed is nominal and will differ from the actual, measurable size.



### AFLB Series Dimensions

## Automatic Pressure Independent Flow Limiter w/ Ball Valve B: AFLB - 1" H - 1½" L

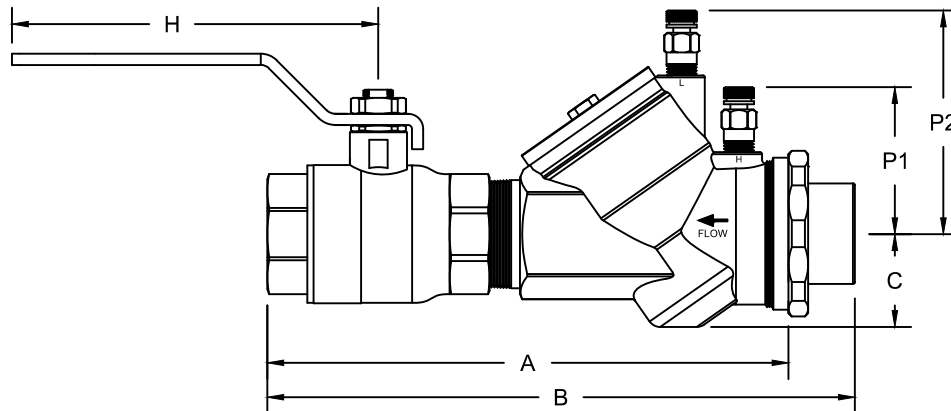

BALL VALVE SIZE AND TYPE	A	TAIL PIECE	B	WEIGHT (lbs)	C	H	P1	P2	W
1" SWT	8.6	- M	10.6	5.3	1.4	5.0	2.3	2.6	3.9
		- F	9.5	5.2					
		- S	9.5	5.1					
1" FPT	8.0	- M	10.0	5.3	1.4	5.0	2.3	2.6	3.9
		- F	8.8	5.2					
		- S	9.0	5.1					
1¼" SWT	9.1	- M	11.0	6.2	1.4	5.0	2.3	2.6	3.9
		- F	11.1	6.3					
		- S	10.5	5.9					
		- M	11.1	6.3					
		- F	10.1	6.0					
		- S	10.2	5.9					
1¼" FPT	8.3	- M	10.3	6.2	1.4	5.0	2.3	2.6	3.9
		- F	9.3	6.0					
		- S	9.6	5.9					
		- M	10.3	6.3					
		- F	9.0	5.8					
		- S	9.5	5.9					
1½" SWT	9.4	- M	11.9	6.5	1.4	6.3	2.5	3.4	3.2
		- F	11.9	6.6					
		- S	10.9	5.9					
		- M	11.9	6.4					
		- F	10.6	6.1					
		- S	10.6	5.9					
1½" FPT	9.0	- M	11.0	6.4	1.4	6.3	2.5	3.4	3.2
		- F	11.0	6.5					
		- S	10.0	5.8					
		- M	11.0	6.3					
		- F	9.7	6.0					
		- S	9.7	5.8					

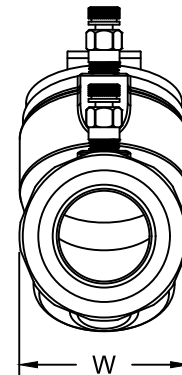

Note: Dimensions listed above do not include ProPress or any other special fittings or adapters. All dimensions, weights, and materials are subject to minor variations. Consult with factory for confirmation of dimensions and material specifications. Sweat size listed is nominal and will differ from the actual, measurable size.



### AFLB Series Dimensions

### Automatic Pressure Independent Flow Limiter w/ Ball Valve

C: AFLB - 1½" H - 2"

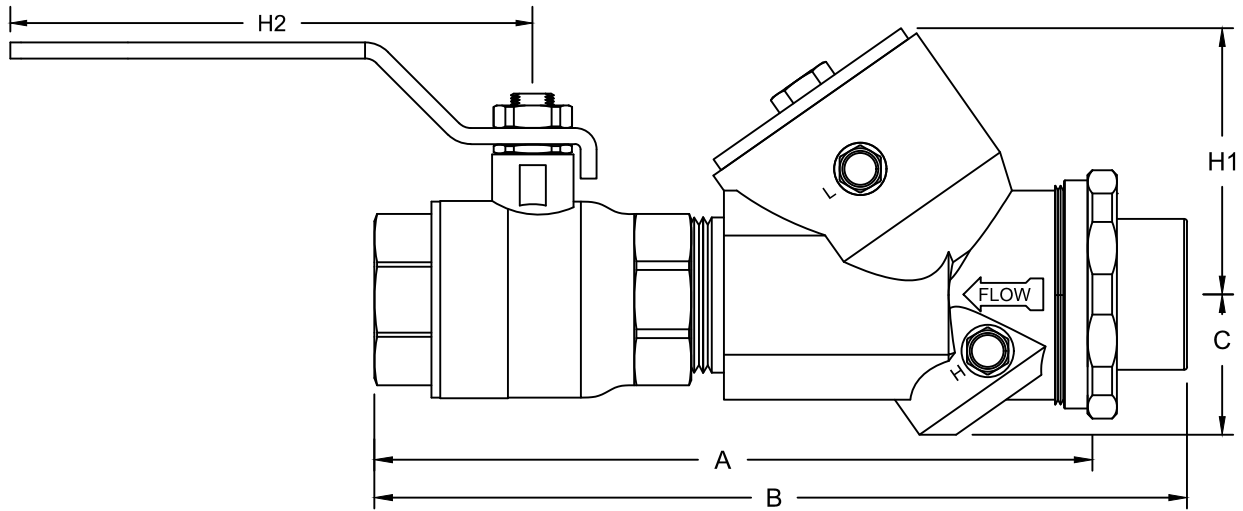

BALL VALVE SIZE AND TYPE	A	TAIL PIECE	B	WEIGHT (lbs)	C	H1	H2	P	W
1½" SWT	12.3	- M	15.3	14.7	2.2	4.2	6.3	3.2	3.7
		1¼" - F	15.3	14.6					
		- S	14.0	13.8					
		1½" - M	15.0	15.1					
		- F	15.3	14.8					
		- S	13.8	13.8					
1½" FPT	11.5	- M	14.5	14.7	2.2	4.2	6.3	3.2	3.7
		1¼" - F	14.5	14.6					
		- S	13.0	13.8					
		1½" - M	14.5	15.1					
		- F	14.5	14.8					
		- S	13.1	13.8					
2" SWT	11.7	- M	14.7	15.5	2.2	4.2	6.2	3.2	3.7
		1½" - F	14.7	15.5					
		- S	13.3	14.6					
		2" - M	14.7	15.5					
		- F	12.8	14.9					
		- S	13.2	14.5					
2" FPT	10.6	- M	13.6	15.4	2.2	4.2	6.2	3.2	3.7
		1½" - F	13.6	15.4					
		- S	12.2	14.5					
		2" - M	13.6	15.4					
		- F	11.8	14.8					
		- S	12.0	14.4					

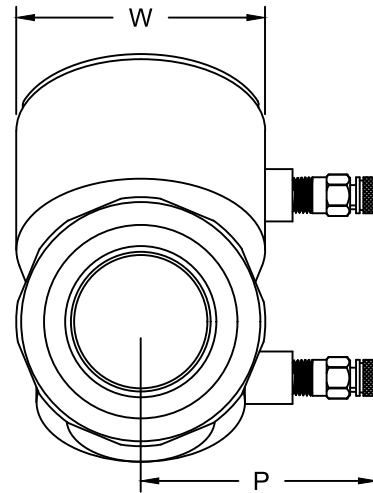

Note: Dimensions listed above do not include ProPress or any other special fittings or adapters. All dimensions, weights, and materials are subject to minor variations. Consult with factory for confirmation of dimensions and material specifications. Sweat size listed is nominal and will differ from the actual, measurable size.

# PRO *Hydronic* *Specialties*

## AFLB Series Submittal

### Automatic Pressure Independent Flow Limiter w/ Ball Valve

- A: AFLB - 1/2" - 1" L
- B: AFLB - 1" H - 1 1/2" L
- C: AFLB - 1 1/2" H - 2"

U.S. Patent No.  
8,061,195

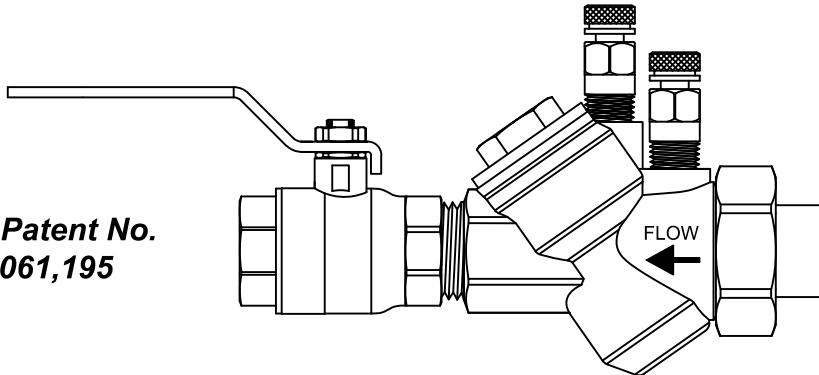

**AFLB - X - X - X - X - X - X - XX,**

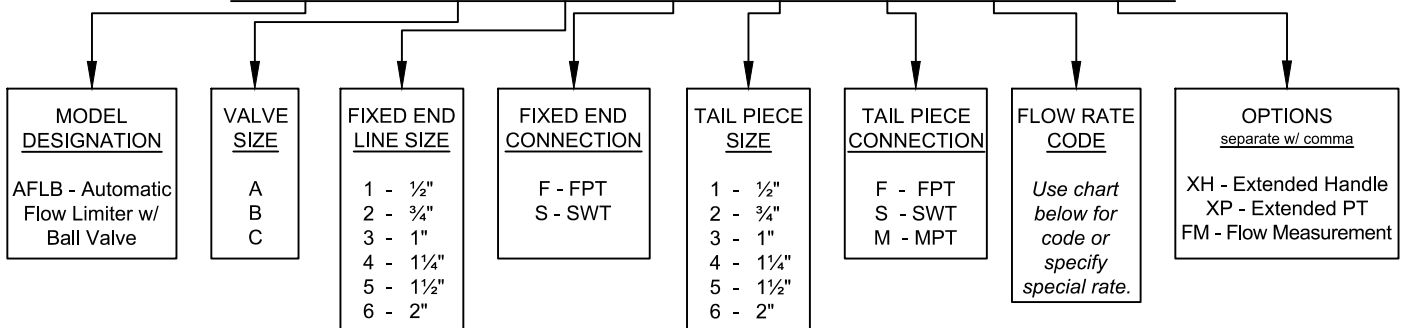

Valve Size	FLOW RATE CODES (GPM)* CONTROL RANGE 2 - 60+ PSID **																									
	A	B	C	D	E	F	G	H	I	J	K	L	M	N	O	P	Q	R	S	T	U	V	W	X	Y	Z
A 1/2" - 1" L	.33	.50	.75	1	1.25	1.5	1.75	2	2.25	2.5	2.75	3	3.5	4	4.5	5	5.5	6	6.5	7	7.5	8	9	10	11	12
B 1" H - 1 1/2" L	5	5.5	6	6.5	7	8	9	10	12	13	14	15	16	18	20	22	24	26	28	30	32	34	36	38	40	42
C 1 1/2" H - 2"	15	20	25	30	35	40	45	50	55	60	65	70	75	80	85	90	95	100	110	120	130	140	150	160	170	180

\* Custom flow rates can be calibrated at the factory for an additional charge.  
 Unless confirmed as special, flow rates will default to standard flow rate.

JOB NAME:		REPRESENTATIVE:	
ENGINEER:		REF/PO#:	
CONTRACTOR:		SUBMITTED BY:	
		DATE:	
		DATE:	
PART # (See table above)	TAGGING/JOB INFORMATION	GPM	QUANTITY