

REJ Series Specifications

Rubber Expansion Joint

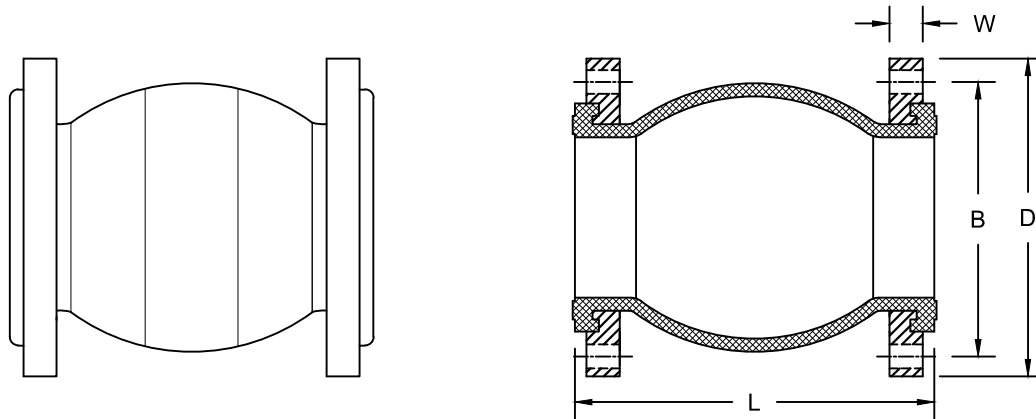

PRODUCT DESCRIPTION: The Model REJ is an EPDM Single Ball rubber expansion joint with ANSI Class 150# Flanges that offers numerous advantages when installed in piping systems. The REJ helps to reduce noise and vibration from mechanical equipment, as well as compensating for misalignment of equipment due to operation and installation. The REJ also provides relief from expansion and contraction of systems due to varying temperatures. Available in 2½", 3", 4", 6" and 8" sizes.

STANDARD MATERIAL SPECIFICATIONS	
Floating Flange	Zinc Plated Low Carbon Steel ASTM A36
Outer & Inner Rubber	EPDM
Pressure Ring	Steel Wire Strand
Rating	225 PSI @ 170°
Specification information is provided to assist and is given without obligation or warranty. The Company reserves the right to make changes in design, materials, and/or specifications without notice or liability.	

PRODUCT SPECIFICATIONS						
PART #	SIZE	B	D	L	W	WEIGHT
REJ250	2½"	5.50	7.00	4.50	0.75	12
REJ300	3"	6.00	7.50	5.00	0.88	14
REJ400	4"	7.50	9.00	6.00	0.88	18
REJ600	6"	9.50	11.00	7.25	1.00	27
REJ800	8"	11.75	13.50	8.00	1.00	40
Note: All dimensions, weights, and materials are subject to minor variations. Consult with factory for confirmation of dimensions, weights, and material specifications at the time of order.						

PRODUCT BENEFITS:

- Noise Reduction
- Vibration Isolation
- Stress Relief from Thermal Expansion
- Erosion and Corrosion Resistant
- Lightweight for Ease in Installation
- No Gasket Required
- REJs can only be used without control rods if the equipment is properly anchored